

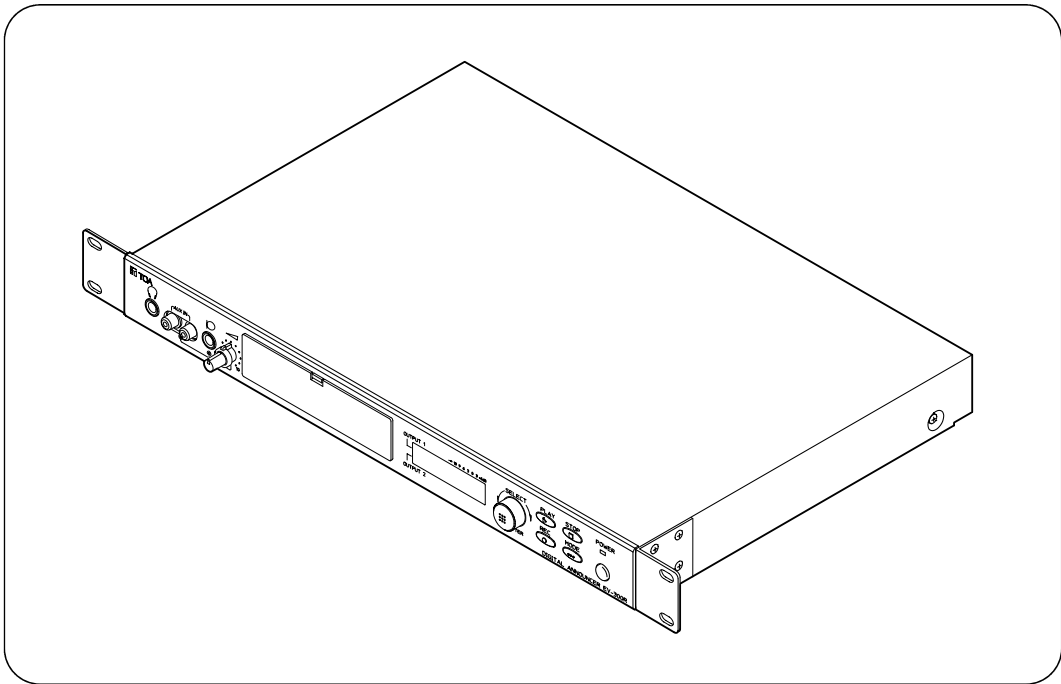

OPERATING INSTRUCTIONS

DIGITAL ANNOUNCER

EV-350R



Please follow the instructions in this manual to obtain the optimum results from this unit.
We also recommend that you keep this manual handy for future reference.

TOA Corporation

TABLE OF CONTENTS

1. SAFETY PRECAUTIONS	6
------------------------------------	---

EQUIPMENT OUTLINE

2. BEFORE OPERATING THE UNIT

2.1. General Description	7
2.2. Features	7
2.3. Handling Precautions	7
2.4. About the Memory Card	
2.4.1. Usable memory cards	7
2.4.2. Usable memory cards vs. maximum per-card recording time (hour:minute:second)	8
2.4.3. Before using the SRAM memory card	8
2.4.4. Inserting and ejecting the memory card	9
2.4.5. Handling precautions for the memory card	9

3. NOMENCLATURE AND FUNCTIONS

[Front Panel]	10
[Rear Panel]	11

4. OUTLINE OF OPERATIONAL FUNCTIONS

4.1. Operation and Screen Display	
4.1.1. Keys and dial to be used in each setting and operation	12
4.1.2. About the screen display.....	12
4.2. Whole Operation Flow (Playback, Recording, and Setting)	13
4.3. Summarized Operational Functions (Recording, Playback, and Setting)	14

5. THE SENTENCE AND PROGRAM

5.1. Sentence	16
5.2. Program	16

RECORDING FUNCTIONS AND OPERATION

6. RECORDING

6.1. Before Recording	
6.1.1. Notes on recording.....	18
6.1.2. Connections	18
6.1.3. Power on	19
6.1.4. Formatting the card (Initial formatting)	19
6.2. Recording Sound Quality	20
6.3. Manual Start Recording and Automatic Start Recording	
6.3.1. Recording method	21
6.3.2. Setting of automatic start recording	21
6.4. Recording the Emergency Sentence	21
6.5. Recording Setting Procedure	22
6.6. Recording Procedure	
6.6.1. Manual start recording	22
6.6.2. Auto start recording	24
6.6.3. Emergency sentence recording	24

PLAYBACK FUNCTIONS AND OPERATION

7. PLAYBACK

7.1. Before Starting Playback

- 7.1.1. Single-source playback mode and dual-source playback mode 26
- 7.1.2. Output display 26

7.2. Manual Playback

- 7.2.1. Operating and connecting sections 27
- 7.2.2. Playback method 27
- 7.2.3. Playback operating procedure
 - [Playback of the program set for output 1] 28
 - [Playback of the program set for output 2] 28
 - [Playback of the program set for outputs 1 and 2] 28
- 7.2.4. Screen display during playback 30
- 7.2.5. Playback program information display 31

7.3. Emergency Playback (External Activation) 32

7.4. Playing Back the Emergency Sentence 32

SETTING FUNCTIONS AND OPERATION

8. SETTING FUNCTIONS

8.1. Setting Functions (1. PROGRAM SETTING)

- 8.1.1. Program input setting (1-1 PROGRAM INPUT) 33
- 8.1.2. Playback Method
 - [Continuous program playback] 34
 - [Single-program playback] 34
 - [Repeat playback] 35
 - [Endless playback] 36
- 8.1.3. Step input, erasure and insertion 37
- 8.1.4. Setting the program output level (1-2 OUTPUT LEVEL) 38
- 8.1.5. Program verification (1-3 PROGRAM VERIFICATION) 38
- 8.1.6. Program initialization (1-4 PROGRAM INITIALIZATION) 38
- 8.1.7. Entering and editing the program title (1-5 PROGRAM TITLE) 38

8.2. Setting Functions (2. EDITING THE SENTENCES)

- 8.2.1. Verifying the sentence (2-1 SENTENCE VERIFICATION) 38
- 8.2.2. Erasing the sentence (2-2 SENTENCE ERASURE) 38
- 8.2.3. Entering and editing the sentence title (2-3 SENTENCE TITLE) 38
- 8.2.4. Erasing the silent areas (2-4 INTERVAL ERASING) 38

8.3. Setting Functions

(3. MONITORING THE SENTENCES AND PROGRAMS)

- 8.3.1. Monitoring the sentence (3-1 SENTENCE MONITORING) 39
- 8.3.2. Monitoring the program (3-2 PROGRAM MONITORING) 39

8.4. Setting Functions (4. OUTPUT/VOLUME SETTING)

- 8.4.1. Selecting single- or dual-source playback mode
 - (4-1 DUAL-SOURCE PLAYBACK SELECTION) 39
- 8.4.2. Master volume setting (4-2 MASTER VOLUME) 39

8.5. Setting Functions (5. OPERATION SETTING)

- 8.5.1. Remote control (5-1 CONTROL FUNCTION SETTING)
 - [Recording/erasure, playback and stop]
 - [Direct mode and binary mode] 40
 - [Activation control inputs 1-8 in direct mode] 40
 - [Activation control inputs 1-8 in binary mode] 41
- 8.5.2. Activation mode for remote control (5-2 ACTIVATION MODE SELECTION) 42

8.5.3. Direct mode	
[Remote recording]	42
[Remote erasure]	43
[Remote playback]	43
[Remote stop]	45
8.5.4. Binary mode	
[Remote recording]	45
[Remote erasure]	46
[Remote playback]	46
[Remote stop]	47
8.5.5. Busy output and playback delay time settings (5-3 BUSY OUTPUT SETTING)	
[Busy output setting]	48
[Playback delay time setting]	48
8.6. Setting Functions (6. ENVIRONMENT SETTING)	
8.6.1. Operation beep setting (6-1 OPERATION BEEP)	48
8.6.2. RS-232C setting (6-2 RS-232C SETTING)	48
8.6.3. Password setting (6-3 PASSWORD)	48
8.6.4. Initializing the digital announcer (6-4 DIGITAL ANNOUNCER INITIALIZATION)	49
8.6.5. Key lock setting (6-5 KEY LOCK)	49
8.6.6. Version indication (6-6 VERSION INDICATION)	49
8.7. Setting Functions (7. EDITING THE CARDS)	
8.7.1. Entering or editing the card name (7-1 CARD NAME INPUT)	49
8.7.2. Reformatting the memory card (7-2 CARD REFORMATTING)	49
8.7.3. Optimization of the cards (7-3 CARD OPTIMIZATION)	49
8.7.4. Software-operated write protection (7-4 SOFTWARE WRITE PROTECT)	49
8.8. Setting Functions (8. COPYING THE PROGRAM, SENTENCE AND CARD)	
8.8.1. Copying a program (8-1 PROGRAM COPYING)	50
8.8.2. Copying a sentence (8-2 SENTENCE COPYING)	50
8.8.3. Copying the memory card (8-3 CARD COPYING)	50
8.8.4. What if an error message is displayed while copying the sentence?	50
8.9. Setting Functions (9. AUTO-LEVEL SETTING)	
8.9.1. Automatic level adjustment (9-1 AUTOMATIC LEVEL ADJUSTMENT)	51
9. SETTING OPERATION	
9.1. An Example of Operation Procedures	52
9.2. Setting Operation (1. PROGRAM)	
9.2.1. Operation procedures (1-1 PROGRAM INPUT)	54
9.2.2. Operation procedures (1-2 OUTPUT LEVEL and 1-3 PROGRAM VERIFICATION)	58
9.2.3. Operation procedures (1-4 PROGRAM INITIALIZATION and 1-5 PROGRAM TITLE)	60
9.3. Setting Operation (2. EDITING THE SENTENCES)	
9.3.1. Operation procedures (2-1 SENTENCE VERIFICATION and 2-2 SENTENCE ERASURE)	62
9.3.2. Operation procedures (2-3 SENTENCE TITLE and 2-4 INTERVAL ERASING)	64
9.4. Setting Operation (3. MONITORING THE SENTENCES AND PROGRAMS)	
9.4.1. Operation procedures (3-1 SENTENCE MONITORING and 3-2 PROGRAM MONITORING)	66
9.5. Setting Operation (4. OUTPUT/VOLUME SETTING)	
9.5.1. Operation procedures (4-1 DUAL-SOURCE PLAYBACK SELECTION and 4-2 MASTER VOLUME)	67

9.6. Setting Operation (5. OPERATION SETTING)	
9.6.1. Operation procedures (5-1 CONTROL FUNCTION SETTING and 5-2 ACTIVATION MODE SELECTION).....	68
9.6.2. Operation procedures (5-3 BUSY OUTPUT SETTING).....	70
9.7. Setting Operation (6. ENVIRONMENT SETTING)	
9.7.1. Operation procedures (6-1 OPERATION BEEP, 6-2 RS-232C SETTING, 6-3 PASSWORD, 6-4 DIGITAL ANNOUNCER INITIALZATION, 6-5 KEYLOCK and 6-6 VERSION INDICATION).....	72
9.8. Setting Operation (7. EDITING THE CARDS)	
9.8.1. Operation procedures (7-1 CARD NAME INPUT and 7-2 CARD REFORMATTING).....	74
9.8.2. Operation procedures (7-3 CARD OPTIMIZATION and 7-4 SOFTWARE WRITE PROTECT).....	76
9.9. Setting Operation (8. COPYING THE PROGRAM, SENTENCE and CARD)	
9.9.1. Operation procedures (8-1 PROGRAM COPYING).....	77
9.9.2. Operation procedures (8-2 SENTENCE COPYING and 8-3 CARD COPYING).....	78
9.10. Setting Operation (9. AUTO-LEVEL SETTING)	
9.10.1. Operation procedures (9-1 AUTOMATIC LEVEL ADJUSTMENT).....	80
9.11. Entering Characters	
9.11.1. Usable characters and commands.....	81
9.11.2. Character/command display and [SELECT] dial operation.....	81
9.11.3. Character input example.....	82

<i>BROADCASTING OPERATION, INSTALLATION AND CONNECTIONS</i>
--

10. MICROPHONE ANNOUNCEMENTS AND SOURCE EQUIPMENT BROADCAST

10.1. Making Microphone Announcements	83
10.2. Making Source Equipment Broadcast	83

11. INSTALLATION

11.1. Connection Examples	
11.1.1. Front panel.....	84
11.1.2. Rear panel.....	84
11.1.3. Terminal block.....	85
11.1.4. Error detection output terminal.....	85
11.2. Mounting the Unit in an Equipment Rack	86
11.3. Attaching Rubber Feet	86

<i>SPECIFICATIONS</i>

12. SPECIFICATIONS	87
---------------------------------	----

1. SAFETY PRECAUTIONS

- Be sure to read the instructions in this section carefully before use.
- Make sure to observe the instructions in this manual as the conventions of safety symbols and messages regarded as very important precautions are included.
- We also recommend you keep this instruction manual handy for future reference.



WARNING

Indicates a potentially hazardous situation which, if mishandled, could result in death or serious personal injury.

When Installing the Unit

- This is a class A product. In a domestic environment this product may cause radio interference in which case the user may be required to take adequate measures.
- Do not expose the unit to rain or an environment where it may be splashed by water or other liquids, as doing so may result in fire or electric shock.
- Use the unit only with the voltage specified on the unit. Using a voltage higher than that which is specified may result in fire or electric shock.
- Do not cut, kink, otherwise damage nor modify the power supply cord. In addition, avoid using the power cord in close proximity to heaters, and never place heavy objects -- including the unit itself -- on the power cord, as doing so may result in fire or electric shock.
- Avoid installing the unit in unstable locations, such as on a rickety table or a slanted surface. Doing so may result in the unit falling down and causing personal injury and/or property damage.

When the Unit is Used

- Should the following irregularity be found during use, immediately switch off the power, disconnect

the power supply plug from the AC outlet and contact your nearest TOA dealer. Make no further attempt to operate the unit in this condition as this may cause fire or electric shock.

- If you detect smoke or a strange smell coming from the unit.
- If water or any metallic object gets into the unit
- If the unit falls, or the unit case breaks
- If the power supply cord is damaged (exposure of the core, disconnection, etc.)
- If it is malfunctioning (no tone sounds.)
- To prevent a fire or electric shock, never open nor remove the unit case as there are high voltage components inside the unit. Refer all servicing to your nearest TOA dealer.
- Do not place cups, bowls, or other containers of liquid or metallic objects on top of the unit. If they accidentally spill into the unit, this may cause a fire or electric shock.
- Do not insert nor drop metallic objects or flammable materials in the ventilation slots of the unit's cover as this may result in fire or electric shock.
- Do not touch a plug or antenna during thunder and lightning, as this may result in electric shock.



CAUTION

Indicates a potentially hazardous situation which, if mishandled, could result in moderate or minor personal injury, and/or property damage.

When Installing the Unit

- Never plug in nor remove the power supply plug with wet hands, as doing so may cause electric shock.
- When unplugging the power supply cord, be sure to grasp the power supply plug; never pull on the cord itself. Operating the unit with a damaged power supply cord may cause a fire or electric shock.
- When moving the unit, be sure to remove its power supply cord from the wall outlet. Moving the unit with the power cord connected to the outlet may cause damage to the power cord, resulting in fire or electric shock. When removing the power cord, be sure to hold its plug to pull.
- Avoid installing the unit in humid or dusty locations, in locations exposed to the direct sunlight, near the heaters, or in locations generating sooty smoke or steam as doing otherwise may result in fire or electric shock.

When the Unit is Used

- Do not place heavy objects on the unit as this may cause the unit to fall or break, which may result in personal injury and/or property damage. In addition, the object itself may fall off and cause injury and/or damage.
- Contact your TOA dealer as to the cleaning. If dust is allowed to accumulate in the unit over a long period of time, a fire or damage to the unit may result.
- If dust accumulates on the power supply plug or in the wall AC outlet, a fire may result. Clean it periodically. In addition, insert the plug in the wall outlet securely.
- Switch off the power, and unplug the power supply plug from the AC outlet for safety purposes when cleaning or leaving the unit unused for 10 days or more. A fire or electric shock may result.

2. BEFORE OPERATING THE UNIT

2.1. General Description

Employing the memory cards as recording media, the unit is a programmable, maintenance-free digital announcer that permits both recording and playback.

2.2. Features

- LCD-displayed operation guides and handy selection dial facilitate recording and playback.
- Holds up to two memory cards.
- The combination of two sampling frequencies (32 kHz and 44.1 kHz) and four recording grades ("Long", "Normal", "High" and "Extremely High") permits selection of up to eight levels of recording sound quality to best suit given situation.
- Recorded sentences can be combined into complete messages and played back as a program.
- Up to 256 programs can be played back.
- Up to 256 or 1,024 sentences (changeable) can be recorded (when two memory cards are installed).
- Two different messages can be simultaneously output to two different locations.
- In emergency situations, emergency messages can be set to override current programs. (Emergency messages must be pre-recorded.)
- Recording, playback, erasure, and stop can be remotely controlled by external equipment.
- Detachable front cover protects the memory cards from tampering.
- Key lock function prevents accidental key setting changes and tampering of the keys.
- Optional emergency power supply panel permits operation even during power failures.
- Built-in timer allows the same message to be repeated at preset time intervals.

2.3. Handling Precautions

- Do not use the unit near heaters or in locations exposed to sunlight. The unit's plastic parts may be deformed or its finish discolored.
- Avoid installing the unit in humid or dusty locations, as doing otherwise may cause the unit's failure.
- When the unit gets dirty with dust or oil, wipe down with a soft, dry cloth. Never use a chemically-processed cleaning towel or volatile liquids, such as benzine and thinner, because the unit's plastic parts may be deformed or its finish discolored.

2.4. About the Memory Card

The memory card to be used in conjunction with the unit is optional. Purchase the card separately from the unit.

2.4.1. Usable memory cards

Two different types of memory card can be used with the unit: ATA flash memory card and SRAM memory card. Note that purely flash memory cards cannot be used.

2.4.2. Usable memory cards vs. maximum per-card recording time (hour:minute:second)

Capacity (byte)	Card type	Long	Normal	High	Extremely High	Maker/Model No.
8M	ATA flash	0:16:26	0:10:57	0:08:13	0:05:29	(TOA/EV-F8M)
20M	ATA flash	0:43:24	0:28:56	0:21:42	0:14:28	(TOA/M-A20M)
40M	ATA flash	1:27:05	0:58:04	0:43:33	0:29:02	(TOA/M-A40M)

Notes

- Contact your TOA dealer as for large-capacity cards of other makers.
- All the cards available for the EV-300R and EV-300P (our conventional models) can be used for this unit.
- Up to two memory cards can be installed in the unit.

2.4.3. Before using the SRAM memory card

[Backup battery installation]

1. Shift the LOCK switch to the left to pull the battery holder out of the card.
2. Place the supplied backup battery in the holder with the [+] side up, then reinsert the holder into the card.

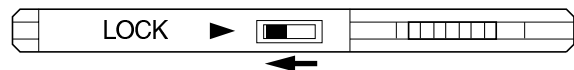

3. Shift the LOCK switch back to the right to lock the holder.

4. Release the write protect switch to enable writing.

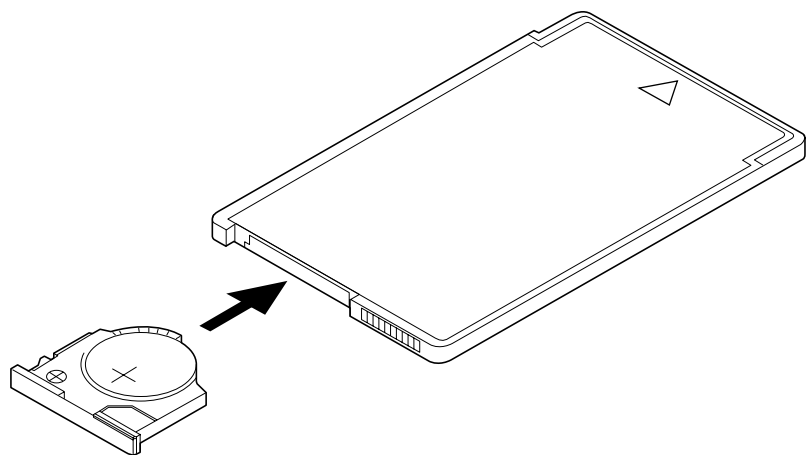

Caution

- If the write protect switch is set to the WP position, the card cannot be used for recording. Use the WP position to avoid the accidental erasure of important recording.
- Note that neither the battery nor the battery holder is supplied with the EV-F series cards.

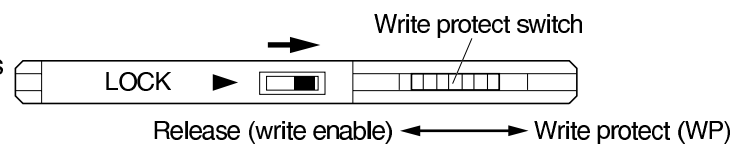

[Backup battery replacement (EV-F series excepted)]

If the battery voltage drops below a marginal level, either of the following indications is displayed on the screen.

CARD A BAT. LOW

CARD A BAT. OUT

Important.

It is suggested that the battery be replaced immediately when the indication of [CARD A BAT. OUT] is displayed.

- Each SRAM memory card (EV-M256, EV-M512, EV-M1024, and EV-M2048) has a built-in auxiliary battery that protects the recorded contents from erasure during the backup battery replacement.
- The auxiliary battery is a rechargeable battery. Charging the battery by inserting it into this unit for 30 minutes or more protects the recorded contents for about ten minutes during the backup battery replacement.
- When replacing the backup battery, be sure to insert the auxiliary battery into this unit (energized state) for 30 minutes or more to keep the auxiliary battery fully charged before replacing.
- Each battery's life is as follows.
 - EV-M256 : Approximately 5 years
 - EV-M512 : Approximately 4 years
 - EV-M1024: Approximately 2 years
 - EV-M2048: Approximately 1 year
- Use the commercial lithium battery BR2325 or CR2325 when replacing the backup battery.

2.4.4. Inserting and ejecting the memory card

Remove the front cover when inserting or ejecting the memory card.

1. Push down the front cover tab to remove the cover.

2. Insert or eject the card as shown in the figures.

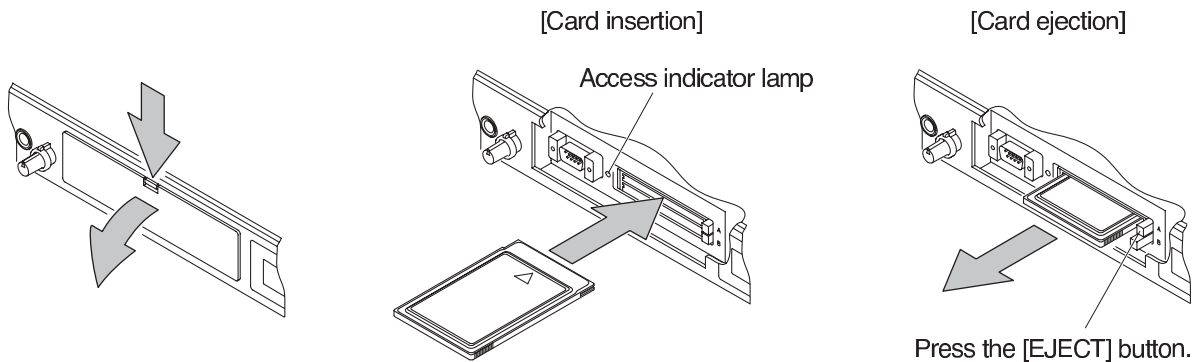

Caution: Do not move the card while the access indicator lamp remains lit or is flashing. Data in the card may be lost.

2.4.5. Handling precautions for the memory card

- Do not use alcohol to clean the surface.
- Do not expose the card to sunlight.
- Replace the battery as soon as it shows a sign of exhaustion. (EV-F series is excepted.)
- Do not get the card wet.
- Put the card in the antistatic envelope (blue) attached to the card when storing. (This also helps prevent foreign matter from accumulating on the edge connector.)

3. NOMENCLATURE AND FUNCTIONS

[Front Panel]

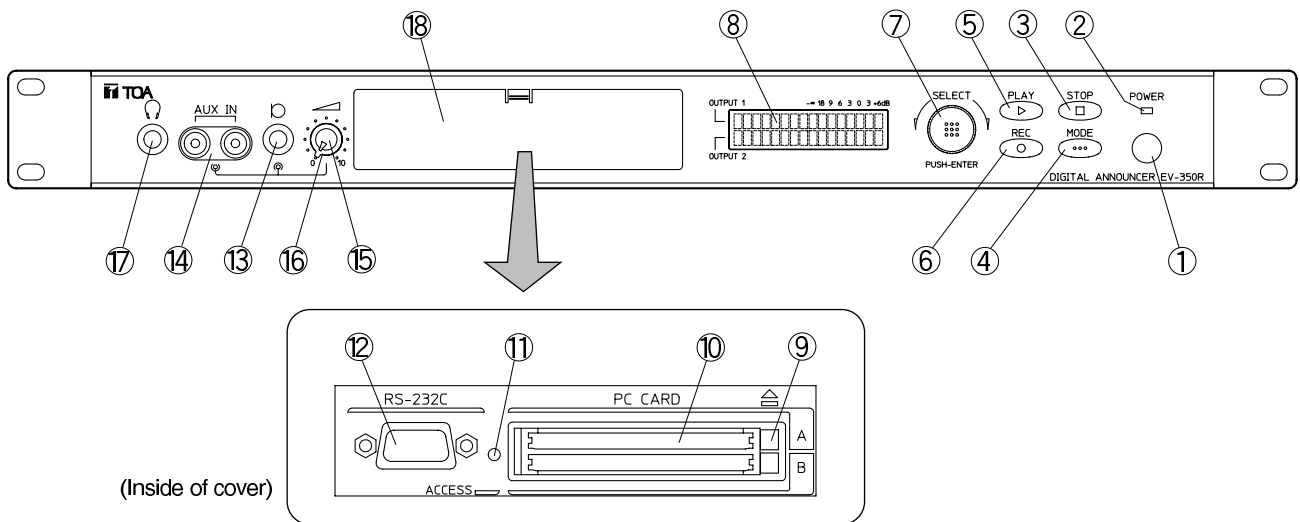

- ① **Power switch**
Power is switched on and off with each depression of this switch.
- ② **Power indicator lamp**
Lights when the power is switched on.
- ③ **Stop key**
Press this key to temporarily stop playback or recording.
- ④ **Mode selector key**
Press this key to switch the initial screen to the setting menu screen. (See p. 12.)
- ⑤ **Playback key**
Press this key when switching the unit from the initial screen display into playback standby, or starting playback of the designated program in playback standby.
When pressed in recording standby or at the setting screen display, the unit falls into playback standby. (See p. 12.)
- ⑥ **Recording key**
Press this key when switching the unit from the initial screen display into recording standby, or starting recording of the designated program in recording standby.
When pressed in playback standby or at the setting screen display, the unit falls into recording standby. (See p. 12.)
- ⑦ **Selection dial**
Selects the operation at recording, playback or setting screen display. (See p. 12.)
- ⑧ **Display screen (LCD)**
Displays recording/playback status, setting contents, etc.
- ⑨ **Eject keys [A, B]**
Eject the card inserted into memory card slots A and B.
- ⑩ **Memory card slots [A, B]**
Memory cards to be used for recording or playback are inserted into these slots.
- ⑪ **Access indicator lamp**
Lights when reading from or writing into the card. To prevent the loss of card data, do not insert nor eject the card while the access indicator lamp remains lit or is flashing.
- ⑫ **RS-232C terminal (D-sub 9-pin male connector)**
Connects to the RS-232C terminal of external equipment.
- ⑬ **Microphone input**
Connects to the microphone to be used for recording or announcement. (See p. 83.)
- ⑭ **Auxiliary input**
Connects to external musical equipment to be used for recording or broadcast.
- ⑮ **Microphone input volume control**
Adjusts the microphone input volume.
- ⑯ **Auxiliary input volume control**
Adjusts the auxiliary input volume.
- ⑰ **Headphones output**
Connects to headphones for monitoring.
- ⑱ **Front cover**

[Rear Panel]

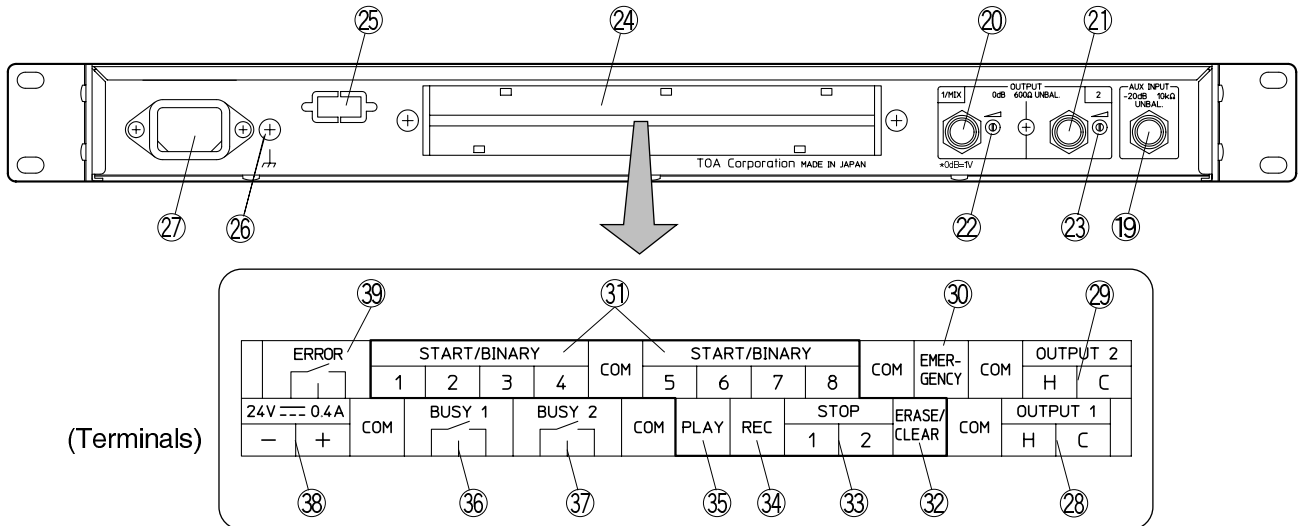

- ①9 **Auxiliary input**
Connects to external musical equipment to be used for recording or broadcast.
- ②0 **Output 1**
Sends out the unit's playback signal, or signals from the microphone input or auxiliary input. (See p. 84.)
- ②1 **Output 2**
Sends out the unit's playback signal, or signals from the microphone input or auxiliary input.
- ②2 **Output 1 volume control**
- ②3 **Output 2 volume control**
- ②4 **Terminal block** (See p. 85.)
- ②5 **RS-232C terminal receptacle**
Permits removal of the RS-232C terminal from the front to rear cover.
- ②6 **Grounding terminal**
Be sure to ground this terminal.
- ②7 **AC inlet**
Connects to the supplied AC power cord.
- ②8 **Output 1**
Sends out the same signal as output 1 ②0 (phone jack). (See p. 84.)
- ②9 **Output 2**
Sends out the same signal as output 2 ②1 (phone jack).
- ③0 **Emergency playback control input**
Shorting this input plays back the emergency message. (See p. 32.)
- ③1 **Activation control inputs 1-8**
Short these inputs when playing back programs or when recording or erasing sentences. (See p. 40.)
- ③2 **Erasure control input**
Short this input when erasing recorded sentences.
- ③3 **Stop control input**
Short this input when stopping recording or playback.
- ③4 **Recording control input**
Short this input when recording sentences.
- ③5 **Playback control input**
Short this terminal when playing back the program by means of binary control.
- ③6 **Busy output 1**
Outputs a make contact signal during playback or recording of the program set for output 1. (See p. 50.)
- ③7 **Busy output 2**
Outputs a make contact signal during playback or recording of the program set for output 2.
- ③8 **24 VDC terminal**
Connects to the 24 VDC power supply. Note that the AC power supply and the 24 VDC power supply cannot be used simultaneously. Make sure that the unit is operated on either power supply.
- ③9 **Error detection output terminal**
Normally closes.
It will open in such case as no memory card is mounted or the unit malfunctions. (See p. 85.)

4. OUTLINE OF OPERATIONAL FUNCTIONS

4.1. Operation and Screen Display

4.1.1. Keys and dial to be used in each setting and operation

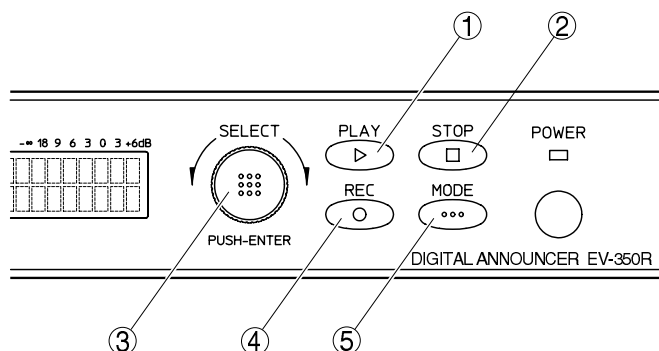

[Keys and dial symbols indicated in the following flow charts]

- Key or dial depression
- Dial rotation

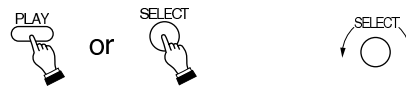

This symbol is the example of "PLAY" key depression.

1. Playback Key

Used for playback operation.

2. Stop Key

- Terminates playback or recording.
- The display returns to the initial screen when the key is pressed at the menu screen, and to the previous menu screen when pressed at the setting screen.

3. Selection Dial

Turning this Dial selects the menu screen, and also the item in the selection area which flashes. Entry is made by pressing on the Dial, which advances the display to the next screen.

4. Recording Key

Used for recording operation.

5. Mode Key

- Pressing this key while the initial screen is displayed places the unit in setting mode and displays the menu screen.
- Press this key when changing the recording sound quality in recording settings.
- The Mode key is also used to display playback program information in playback standby status or during playback.

4.1.2. About the screen display

This Program Input screen example explains the selection screen display.

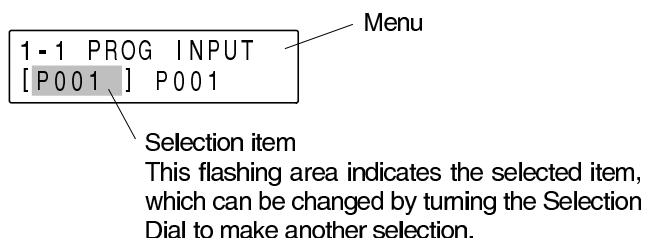

The message as shown below is displayed if no card is inserted into the unit when the power is switched on. In such cases, insert the card as instructed.

CARD NOT SET.
INSERT CARD.

4.2. Whole Operation Flow (Playback, Recording, and Setting)

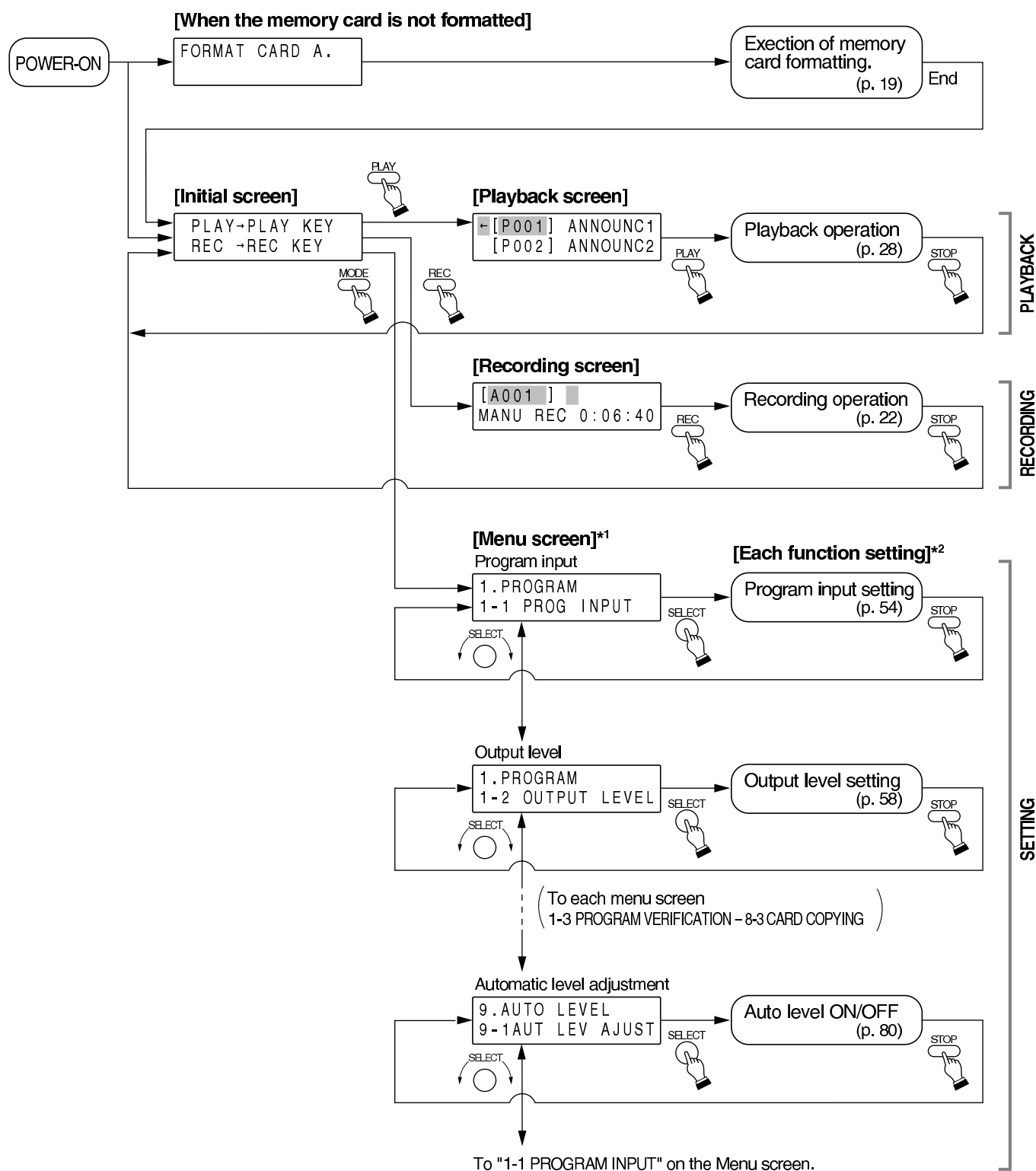

*1 Pressing the [STOP] key while the menu screen is displayed returns the display to the initial screen.

*2 Pressing the [STOP] key while the function setting screen is displayed returns the display to the previous menu screen.

Note: When the function setting is completed, the screen returns to the menu screen. To terminate all setting operations, further press the [STOP] key to return to the initial screen.

4.3. Summarized Operational Functions (Recording, Playback, and Setting)

[Recording]

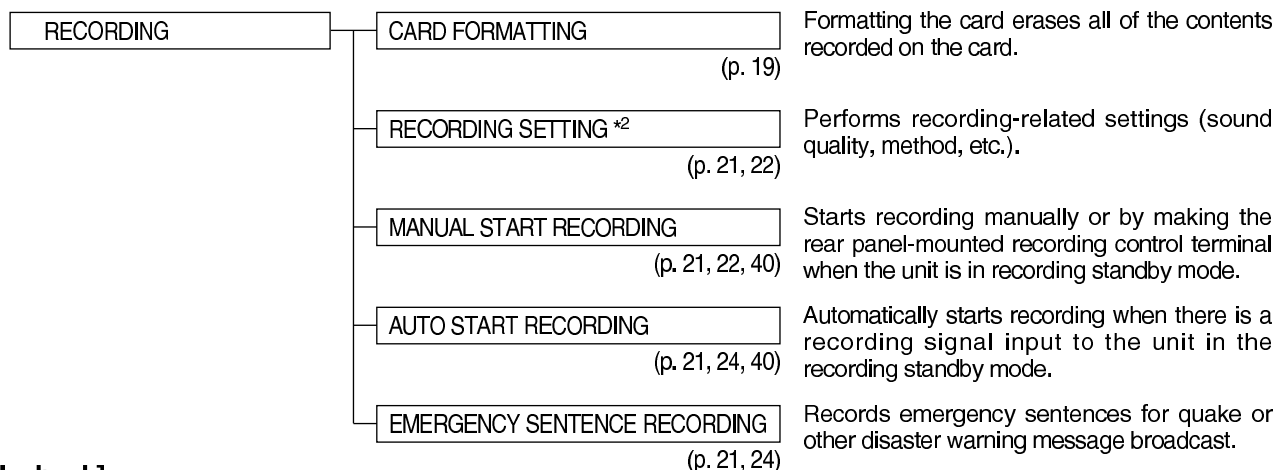

[Playback]

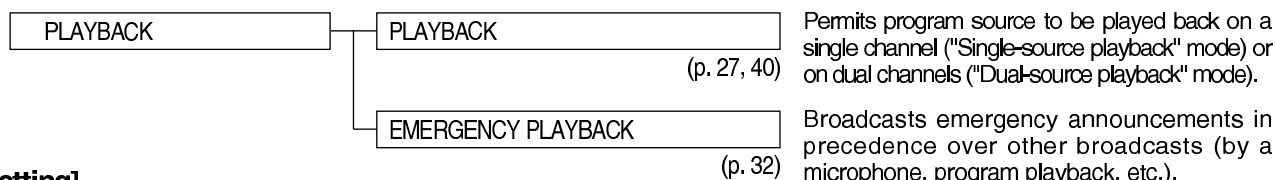

[Setting]

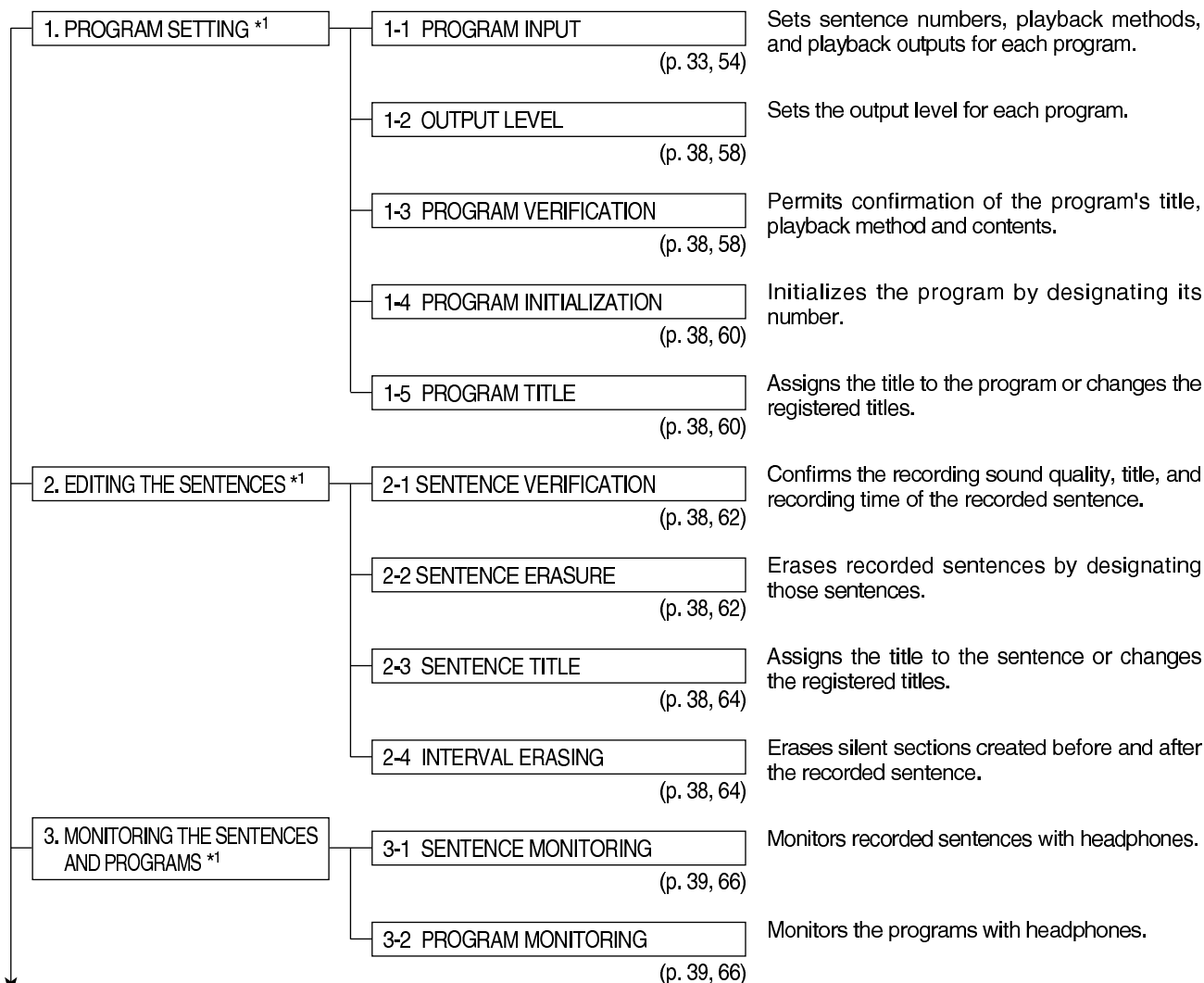

To the next page

Continued from the previous page

4. OUTPUT/VOLUME SETTING *2	<p>4-1 DUAL-SOURCE PLAYBACK SELECTION (p. 39, 67)</p> <p>4-2 MASTER VOLUME (p. 39, 67)</p>	<p>Selects the program playback mode: "Single-source playback" or "Dual-source playback" mode.</p> <p>Sets the overall program playback volume.</p>
5. OPERATION SETTING *2	<p>5-1 CONTROL FUNCTION SETTING (p. 40, 68)</p> <p>5-2 ACTIVATION MODE SELECTION (p. 42, 68)</p> <p>5-3 BUSY OUTPUT SETTING (p. 48, 70)</p>	<p>Selects the remote control method: "Direct" or "Binary" control.</p> <p>Sets activation mode of remote recording, remote playback, and remote stop.</p> <p>Sets the busy output for ON or OFF when playing back the program, recording/erasing the sentence, making an announcement, and setting the system.</p>
6. ENVIRONMENT SETTING *2	<p>6-1 OPERATION BEEP (p. 48, 72)</p> <p>6-2 RS-232C SETTING (p. 48, 72)</p> <p>6-3 PASSWORD (p. 48, 72)</p> <p>6-4 DIGITAL ANNOUNCER INITIALIZATION (p. 49, 72)</p> <p>6-5 KEY LOCK (p. 49, 72)</p> <p>6-6 VERSION INDICATION (p. 49, 72)</p>	<p>Sets whether or not to sound a beep when operating the keys.</p> <p>Sets the RS-232C communication speed.</p> <p>Setting a password and enabling the Key Lock function prevent equipment malfunction and tampering with the keys.</p> <p>Simultaneously resets all settings for factory-preset initial values.</p> <p>If the Key Lock function is enabled (ON), the keys and dial other than the power switch cannot be used.</p> <p>Displays the equipment program software version.</p>
7. EDITING THE CARDS *1	<p>7-1 CARD NAME INPUT (p. 49, 74)</p> <p>7-2 CARD REFORMATTING (p. 49, 74)</p> <p>7-3 CARD OPTIMIZATION (p. 49, 76)</p> <p>7-4 SOFTWARE WRITE PROTECT (p. 49, 76)</p>	<p>Assigns a name to the recorded card or changes the registered name.</p> <p>Formatting the card erases all data recorded on the card.</p> <p>When the sentence recorded on the card is erased, the card recording time could be shortened. This can be avoided by optimizing the card.</p> <p>Protects data recorded or registered into the card.</p>
8. COPYING THE PROGRAM, SENTENCE AND CARD *1	<p>8-1 PROGRAM COPYING (p. 50, 77)</p> <p>8-2 SENTENCE COPYING (p. 50, 78)</p> <p>8-3 CARD COPYING (p. 50, 78)</p>	<p>Copies the created program to other program number.</p> <p>Copies the new recorded sentence to the new sentence number.</p> <p>Copies all card contents to other card.</p>
9. AUTO-LEVEL SETTING *2	<p>9-1 AUTOMATIC LEVEL ADJUSTMENT (p. 51, 80)</p>	<p>Permits uniform sound level even if the program consisting of sentences with different recording levels is played back.</p>

*1 The set data is registered on the memory card.

*2 The set contents are registered in the unit.

5. THE SENTENCE AND THE PROGRAM

5.1. Sentence

- The sentence is the minimum unit of recording data that the Digital Announcer handles. One sentence is created per recording.
- Every sound source, such as a message, chime tone and background music, can be recorded into the sentence.
- Up to 128 sentences (at the initial formatting) can be recorded per card when recording manually or remotely.
The maximum number of sentences that can be recorded can be set for 128 or 512 when reformatting the memory card.
- The sentence number is A001-A128 (or A512) when recorded on the Slot A card, and B001-B128 (or B512) when recorded on the Slot B card. However, if the recorded Slot A card is inserted into Slot B, the number changes from A001-A128 (or A512) to B001-B128 (or B512).
- The title of up to eight characters (alphanumeric characters and symbols) can be assigned to each sentence.
- When the card is inserted into both Slots A and B, the maximum recording time is a sum of the recording time of both cards. Note that a single sentence cannot be recorded over two cards.
- You cannot record in excess of the card's recording time even if the number of sentences recorded is less than 128 or 512 the maximum number of sentences that can be recorded.

5.2. Program

- The program is playback data consisting of Playback Sound Data*¹ and Control Data*². The program is written into a card.
 - *¹ Combined data of Sentence and Silent Interval.
 - *² Comprised of the Playback Method, Output Channel (output 1, output 2 or outputs 1 and 2), Title and Output level (volume).
- Up to 128 steps of the Sentence and Silent Interval can be combined for the Playback Sound Data of one program. The step refers to the sequence of playback.
- The title of up to eight characters (alphanumeric characters and symbols) can be assigned to each program.
- Up to 256 programs (P001-P256) can be input regardless of whether the number of cards inserted is one or two.
- The Silent Interval time of 0-127 seconds can be input, which is adjustable in 0.1-second units if the interval time is 0-10 seconds, and in 1-second unit if 10-127 seconds.
- To play back sounds, designate the program. Playback cannot be achieved by designating the sentence.

Contents to be entered into the program

Data	Content
Playback sound data	Combination of sentence and silent interval (maximum 128 steps)
Control data	Playback method (one of the four methods)
	Output (from output 1 or output 2 or simultaneously from both)
	Program name (program title)
	Program sound volume

Note: If data is not entered, the program is played back as initially set at the factory. (Refer to p. 33 for details.)

Up to 256 programs can be input using the unit (regardless of the number of cards to be used). Sentences to be used in the program can be read from either of the cards inserted into Card Slots A and B.

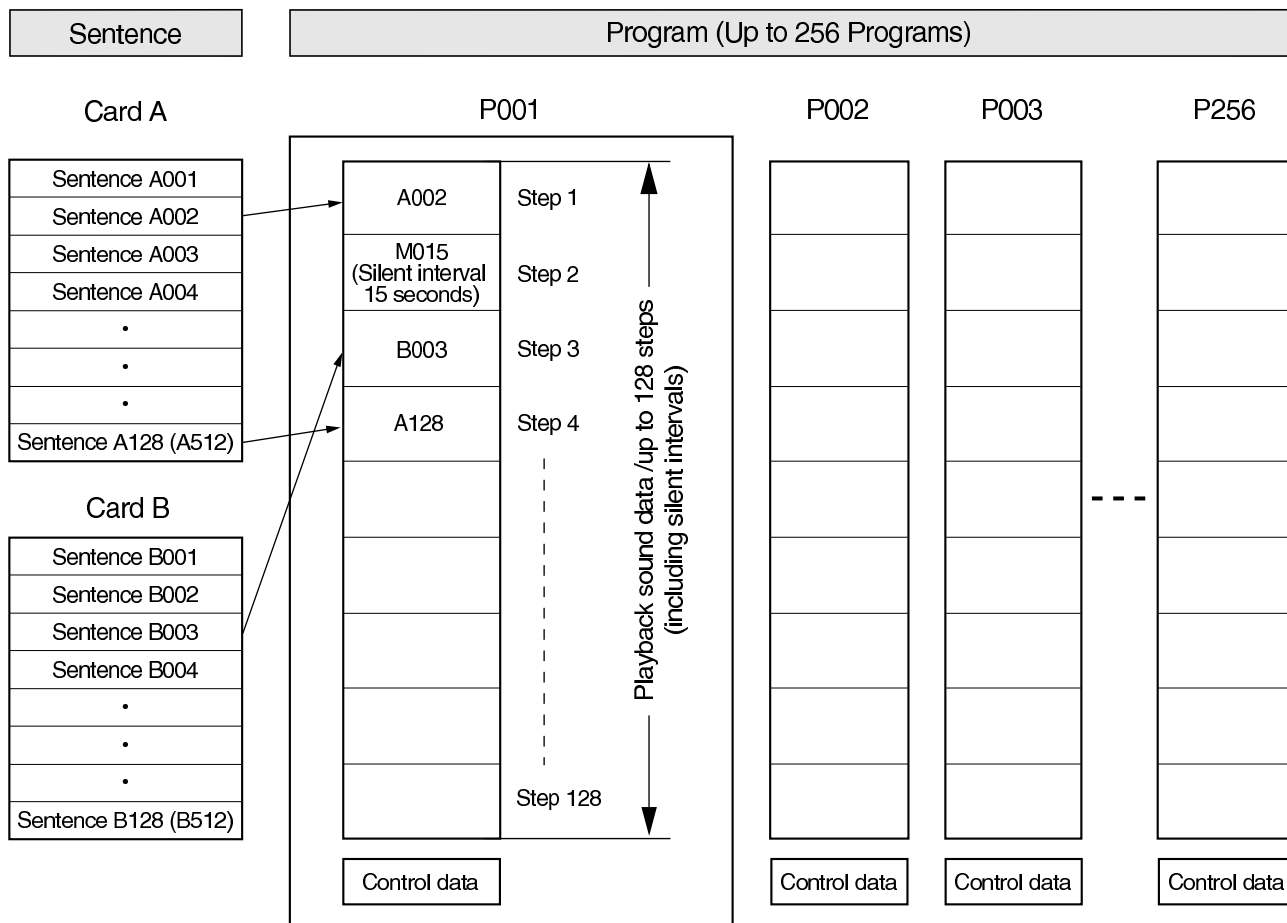

For details of the "Control data," refer to p. 33 "1. PROGRAM SETTING."

6. RECORDING

6.1. Before Recording

6.1.1. Notes on recording

There are some types of memory cards which cannot be used with the unit (refer to p. 7). If such an unusable card is installed, the screen will tell you to the effect that the card cannot be used. The same indication is also displayed if the card installed is broken even though it is of correct type. In such cases, replace the memory card. Note that the memory card must be formatted whenever recording on the new card.

The use of your recording is strictly limited to your personal purposes only. If you use it for any commercial purposes without obtaining the approval from the copyright holder, you will be punished for violation of the Copyright Act.

6.1.2. Connections

Connect the microphones for recording or external musical equipment to be used as a recording sound source.

Note: Simultaneously recording multiple source equipment connected to the unit mixes all inputs from such equipment.

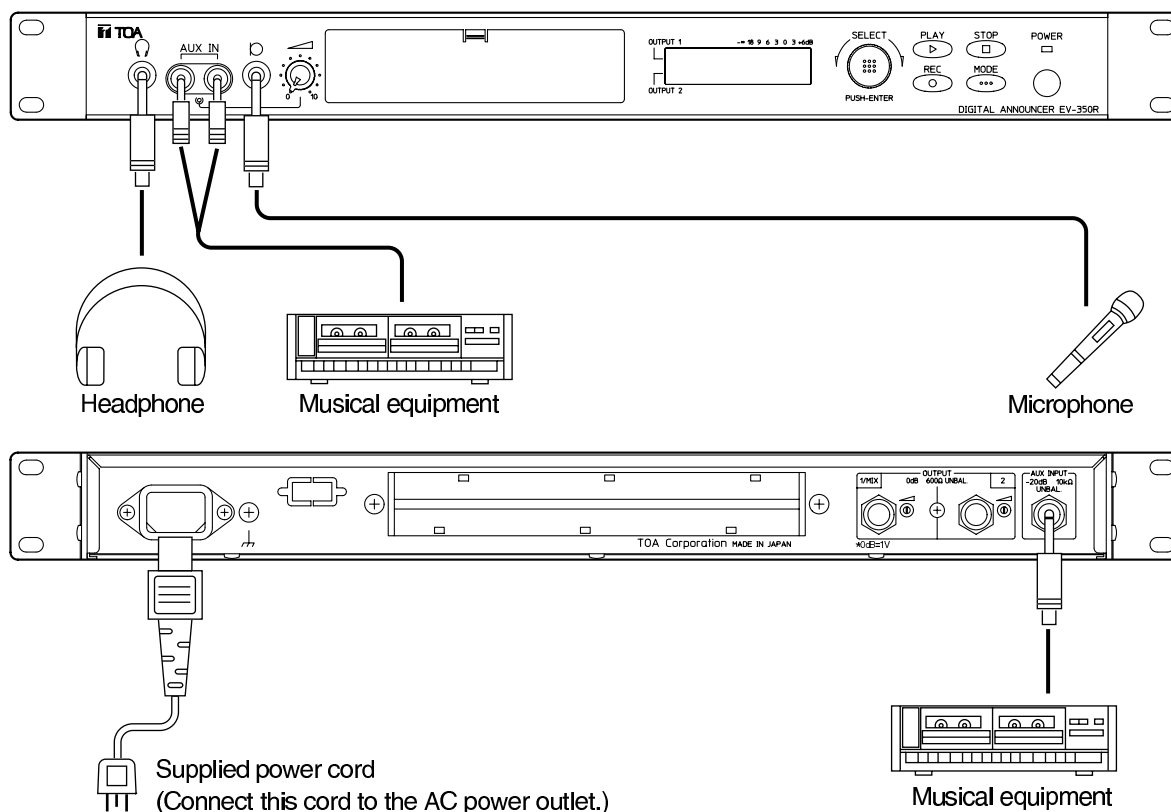

6.1.3. Power on

Insert the memory card (refer to p. 9), then switch on the power. The initial screen appears on the front-located display screen.

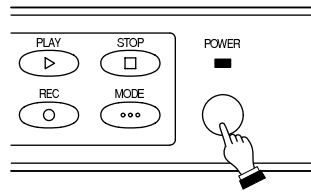

[Initial screen]

PLAY→PLAY KEY
REC →REC KEY

6.1.4. Formatting the card (Initial formatting)

The warning message is displayed when the card not formatted is installed in the unit. Cards not formatted cannot be used with the unit.

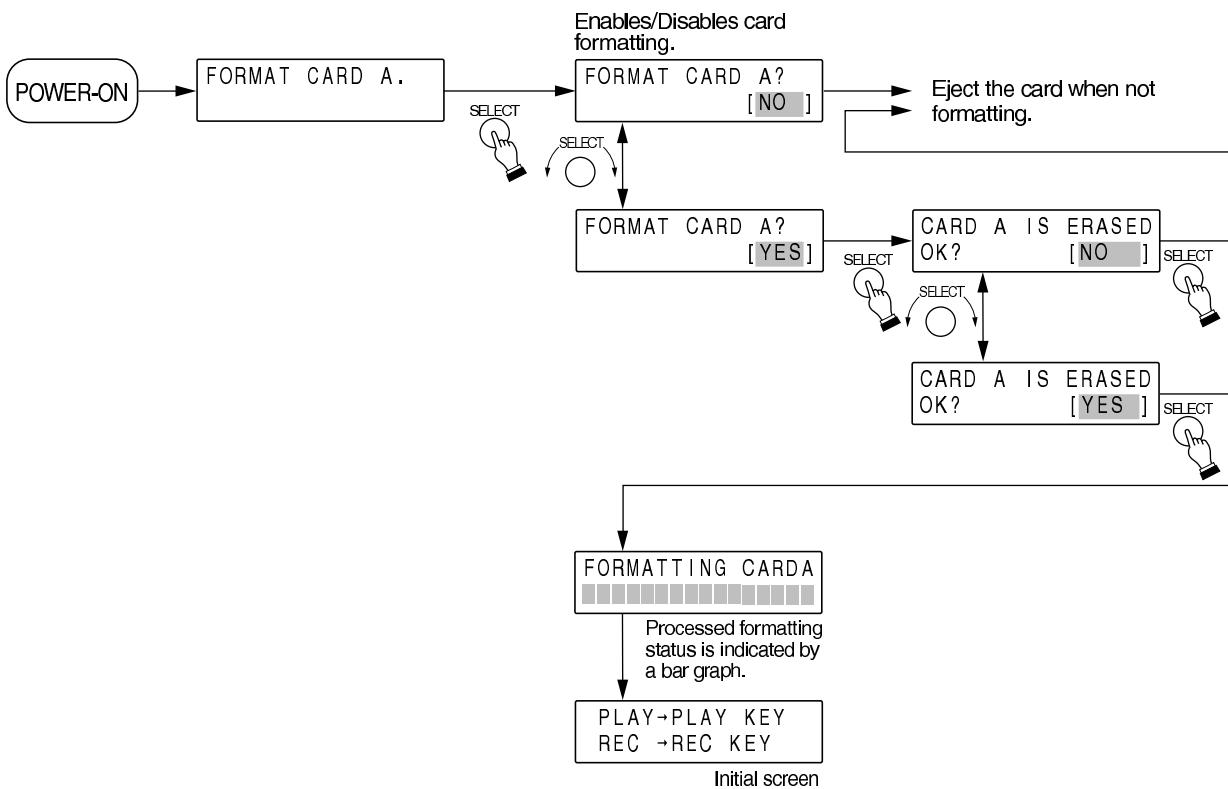

- Follow the above procedure when Card B is not formatted, either. (The indication of Card A changes to Card B.) If neither Card A nor Card B is formatted, the formatting instructions of Card A are first displayed as shown above, followed by the instructions of Card B.
- The maximum number of sentences that can be recorded is 128 when using the card formatted for the first time. Refer to p. 49, 74 “7-2 CARD REFORMATTING” when changing its number to 512.

6.2. Recording Sound Quality

Eight different types of recording sound quality are made available to the unit, so that you can select the sound quality best suited to given situation depending on the type of recording sound source, recording time, and type of memory card to use.

Sampling frequency	Recording grade			
32 kHz	Long	Normal	High	Extremely high
44.1 kHz	Long	Normal	High	Extremely high

If the recording grade is selected, the unit begins to record audio signals compressed using the following bit rates:

Recording grade	Long	Normal	High	Extremely high
Bit rate	64 kbps	96 kbps	128 kbps	192 kbps

- Even though the recording grade is the same, the sound quality of the 32 kHz sampling frequency is higher, although its reproducing frequency range is narrower than that of 44.1 kHz sampling frequency.
- Sampling frequency vs. reproducing frequency range
 Sampling frequency 32 kHz : Reproducing frequency range 20 Hz - 14 kHz
 Sampling frequency 44.1 kHz: Reproducing frequency range 20 Hz - 20 kHz

Recording grade and recording time

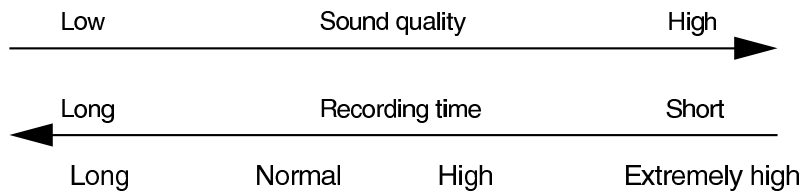

Sampling frequency vs. reproducing frequency range

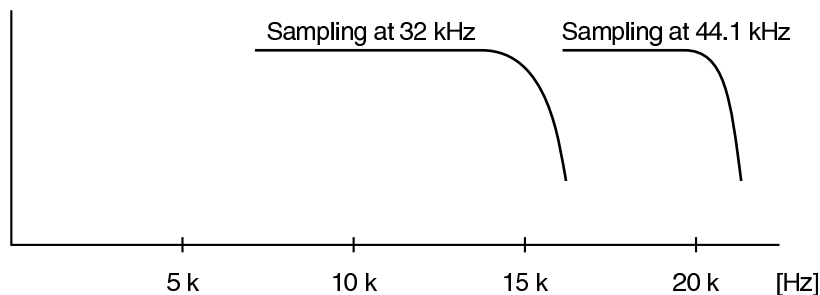

- Recording grade and sampling frequency can be set individually for each sentence (recording unit) in one memory card. Because the recording sound quality best suited to each sentence can be selected individually, the card can be efficiently used for recording.
- It is possible to combine sentences recorded using different recording grades and sampling frequencies, and play back such sentences as a program (playback unit).

Applications of the recording sound quality

The following table provides the guidelines on the selection of the sound quality.

Recording grade	Applications
Long	Recording of announcements or messages
Normal	BGM, chime or signal tones
High	Recording of music
Extremely High	Recording of music that requires higher sound quality than in High.

- For the sampling frequency, usually use 32 kHz. In this event, the frequency response is 20 Hz-14 kHz.
- When requiring the frequency response of 20 Hz-20 kHz, use the sampling frequency of 44.1 kHz.

6.3. Manual Start Recording and Automatic Start Recording

6.3.1. Recording method

There are two different methods to start recording: manual start and automatic start.

Manual start	Recording starts instantly when the [REC] key is pressed or when the rear-mounted recording control terminals are shorted in recording standby mode.
Automatic start	Recording automatically starts when a recording input signal is input after switching the mode from recording standby to input waiting mode by pressing the [REC] key or shorting the rear-mounted recording control terminals.

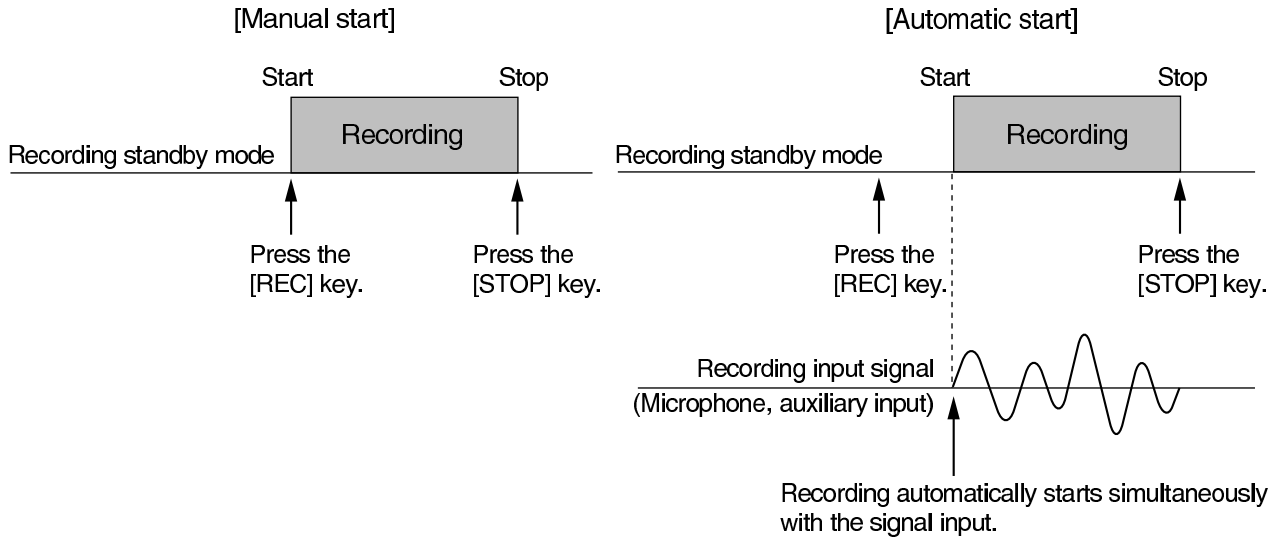

Note: The method is factory-preset for manual start recording.

6.3.2. Setting of automatic start recording

This function is enabled by setting the recording method for this mode. (Refer to p. 22)

The level at which recording starts automatically can be set.

[Levels to automatically start recording]

The "Automatic start recording" method permits the unit to automatically start recording with the recording input signal level set for "Small," "Medium," or "Large."

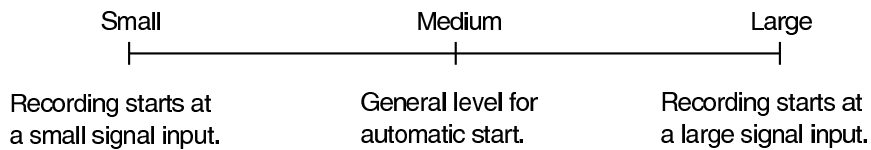

6.4. Recording the Emergency Sentence

[Card slot for the emergency sentence recording]

- The emergency sentence is recorded on the slot A memory card when two cards are inserted into both slots A and B. Also, the emergency sentence is recorded on the slot A memory card when the card is only inserted into slot A, and on the slot B memory card when only inserted into slot B.

[Remarks]

- It is impossible to copy the emergency sentence.
- It is impossible to change the emergency sentence title. (Refer to p. 24 "Emergency sentence recording.")

6.5. Recording Setting Procedure

Perform necessary settings before recording.

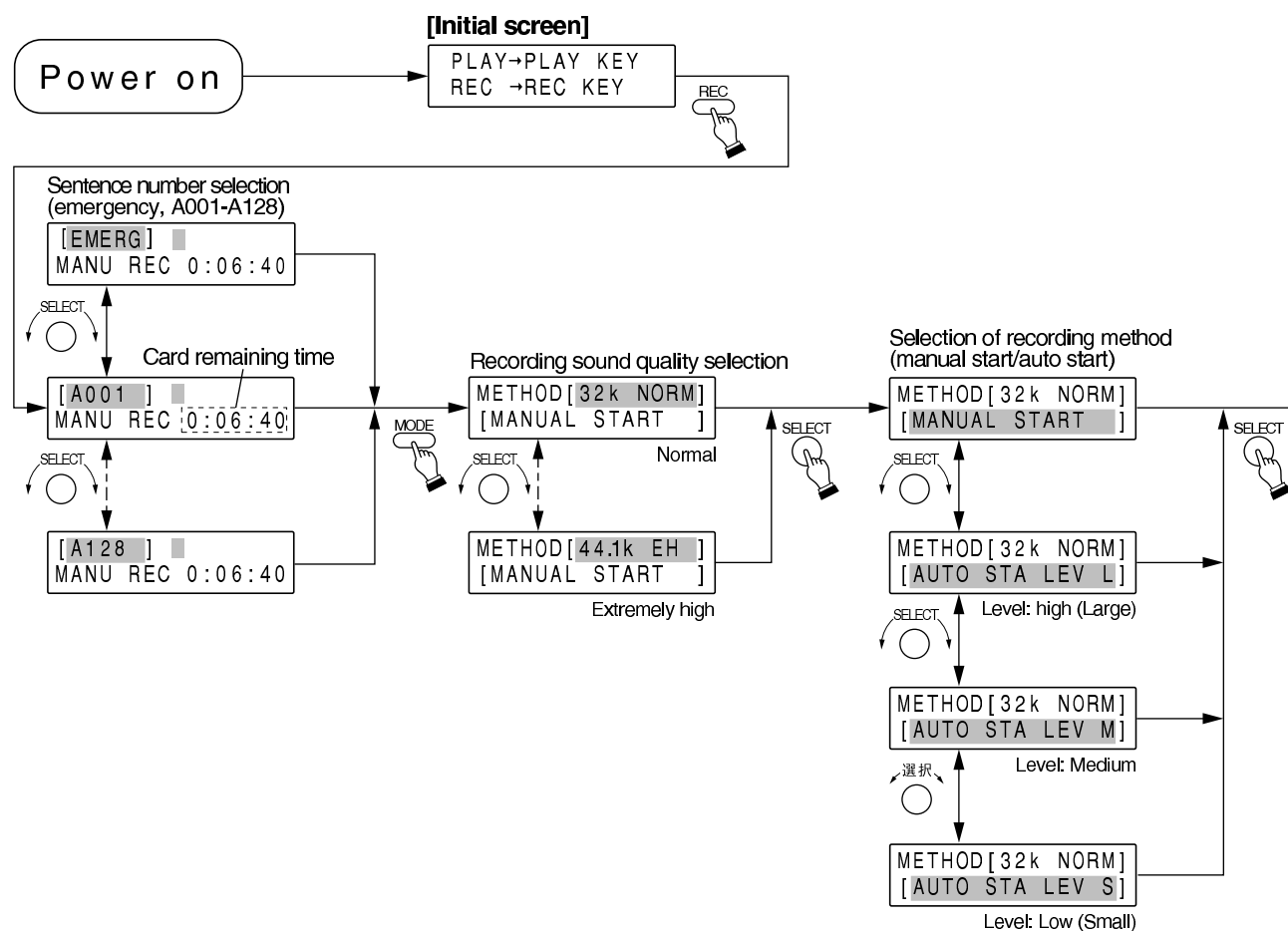

6.6. Recording Procedure

For the remotely-controlled recording, refer to P. 40 “5-1 CONTROL FUNCTION SETTING” [Recording/ erasure, playback and stop].

6.6.1. Manual start recording

Set the recording method for "Manual" start in the above setting.

Also, set both the microphone and auxiliary input volume controls for the "0" (minimum) position.

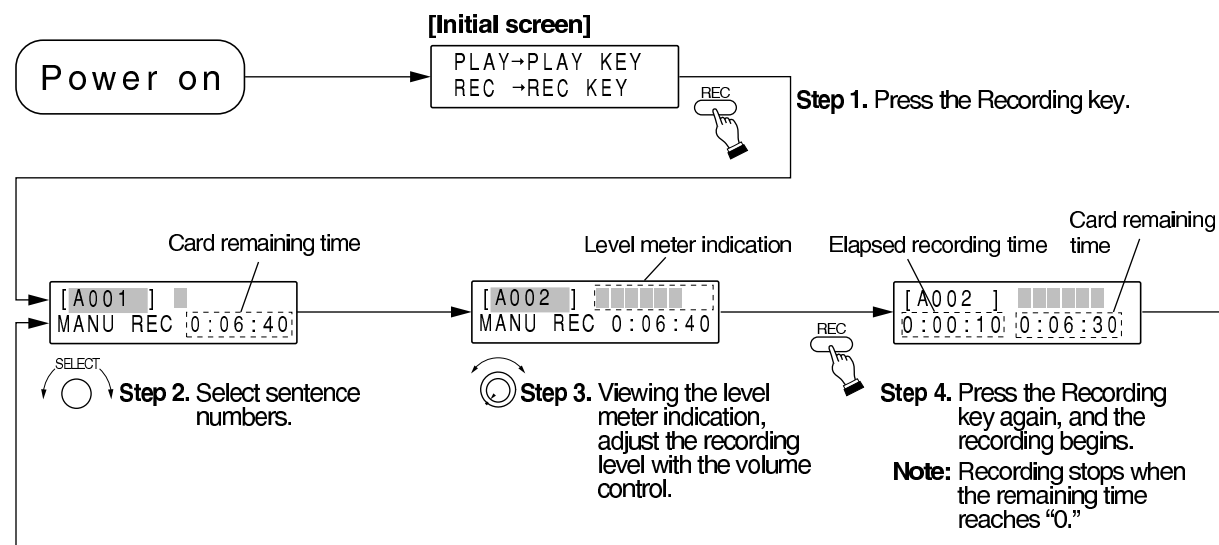

Selection of "Change" or "No change" of the recording method.

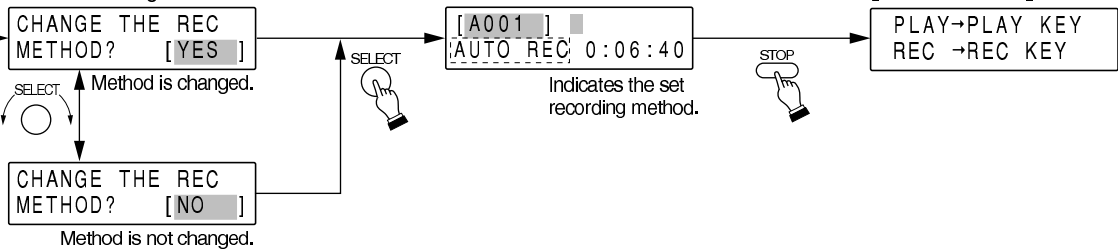

[Selection item]

Recording Sound Quality		Recording Method
32k Normal	44.1k Normal	Manual start
32k Long	44.1k Long	Auto start Level "High"
32k High	44.1k High	Auto start Level "Mid"
32k Extremely high	44.1k Extremely high	Auto start Level "Low"

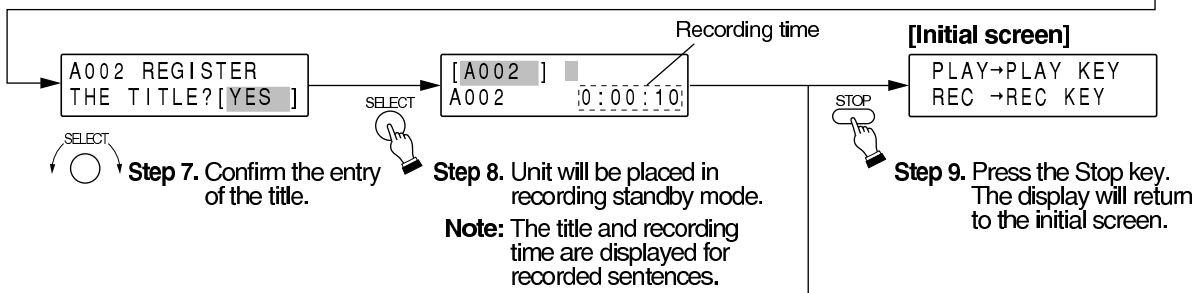
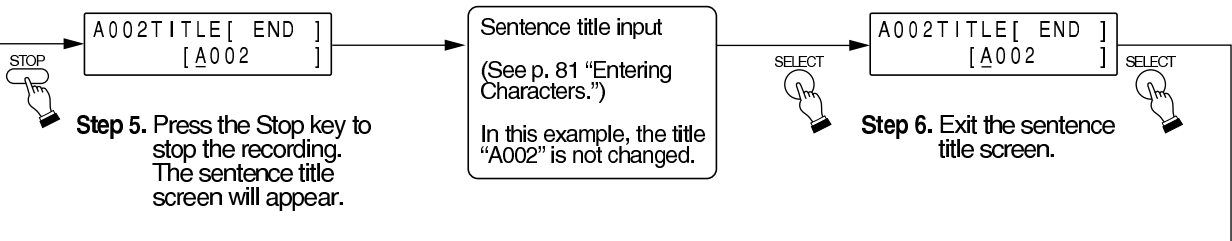

When continuing to record

6.6.2. Auto start recording

Set the recording method for "Auto start." (Refer to p. 22.)

Also, adjust the recording level to the appropriate level with the microphone and auxiliary input volume controls.

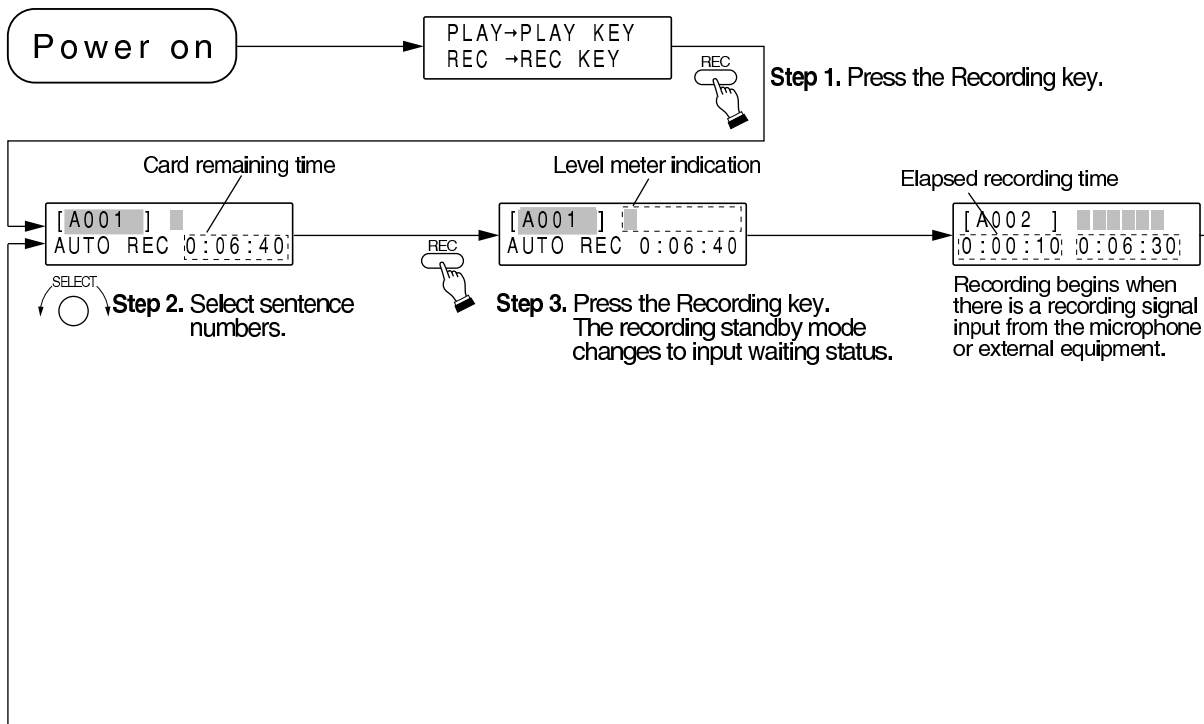

6.6.3. Emergency sentence recording

Adjust the recording level to the appropriate level with the microphone and auxiliary input volume controls.

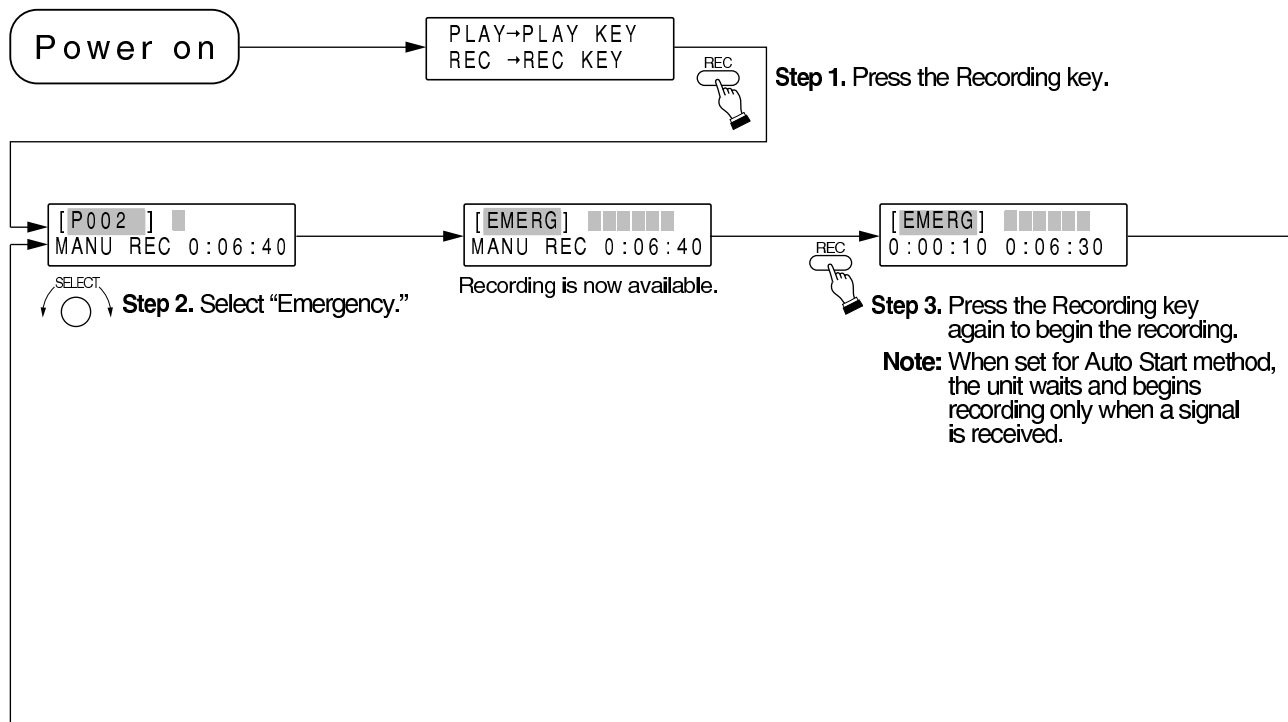

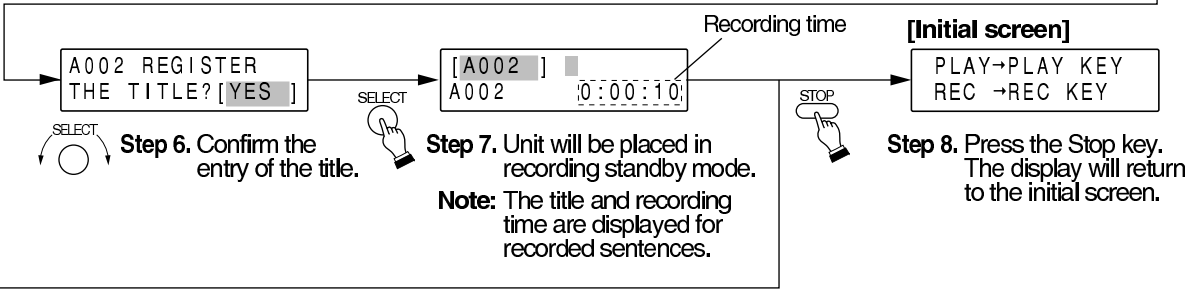
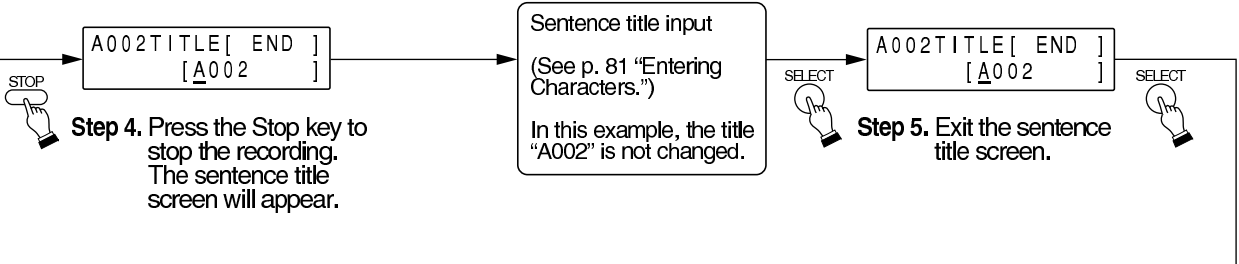

When continuing to record

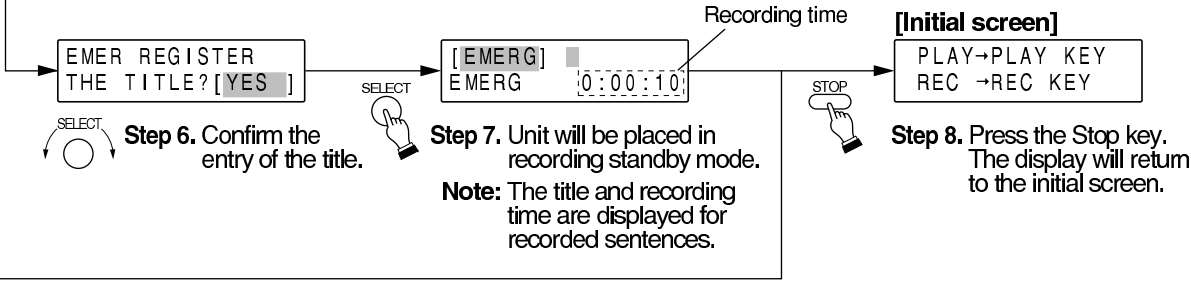
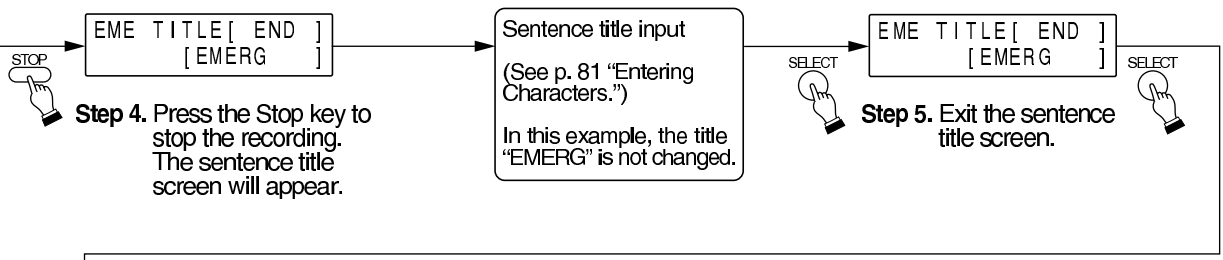

When continuing to record

7. PLAYBACK

Playback begins by designating the program. (Refer to p. 16.)

Input the program before starting playback. (Refer to p. 33.)

7.1. Before Starting Playback

7.1.1. Single-source playback mode and dual-source playback mode

The unit comes with two outputs, 1 and 2, which can be designated for individual programs.

[Single-source playback mode]

Programs are played back only from Output 1 regardless of output settings. Simultaneously playing back two programs set for Outputs 1 and 2 causes the mixed program to be played back from Output 1.

[Dual-source playback mode]

Different playback tones of individual programs can be broadcast from their designated outputs.

Note: The unit is preset for dual-output playback mode. Refer to p. 39 when switching it to single-source playback mode.

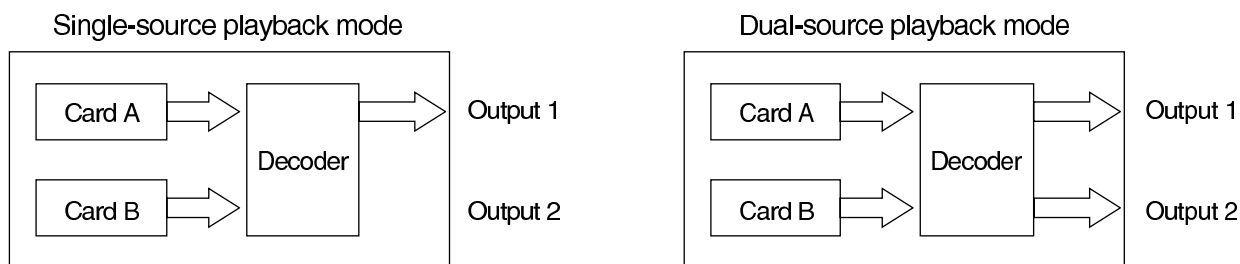

7.1.2. Output display

[Program display]

When the unit is in playback standby mode, both the program number and program title of the program to be played back are displayed. The program set for Output 1 is displayed on the upper row of the screen, while the program set for Output 2 is displayed on the lower row. The program set for both outputs 1 and 2 is displayed on both the upper and lower rows.

[Selected output display]

The arrow is displayed on the left-hand side of the screen during playback or playback standby mode. The arrow indication cycles through the upper row, lower row and both rows as the [SELECT] dial is pressed.

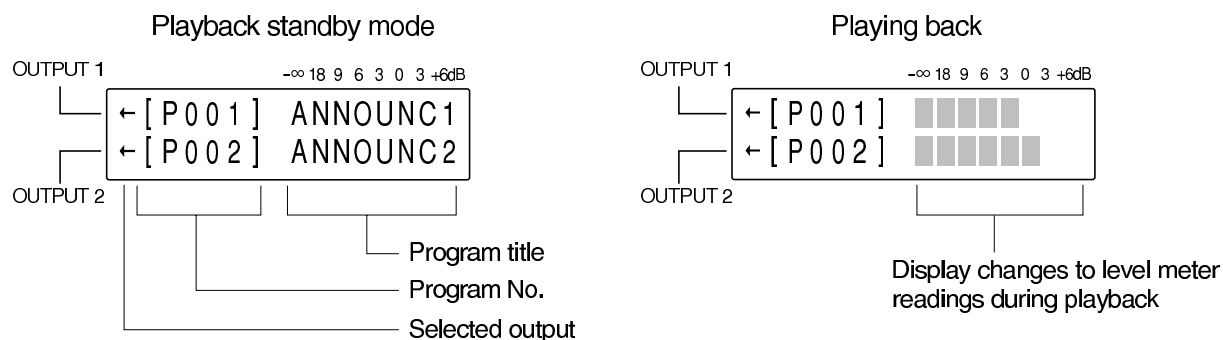

7.2. Manual Playback

For the remotely-controlled playback, refer to p. 40 "5-1 CONTROL FUNCTION SETTING" [Recording/ erasure, playback and stop].

7.2.1. Operating and connecting sections

[Front]

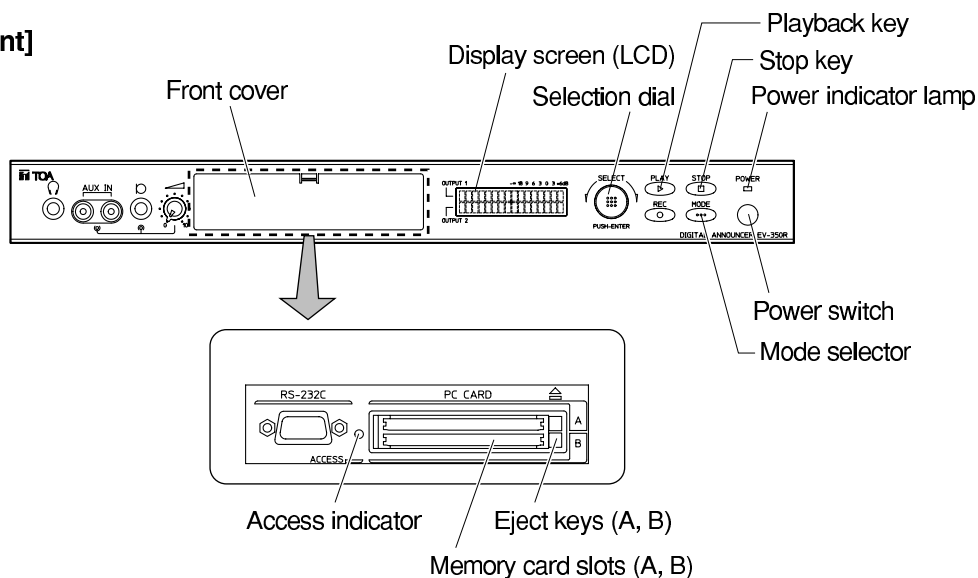

[Rear]

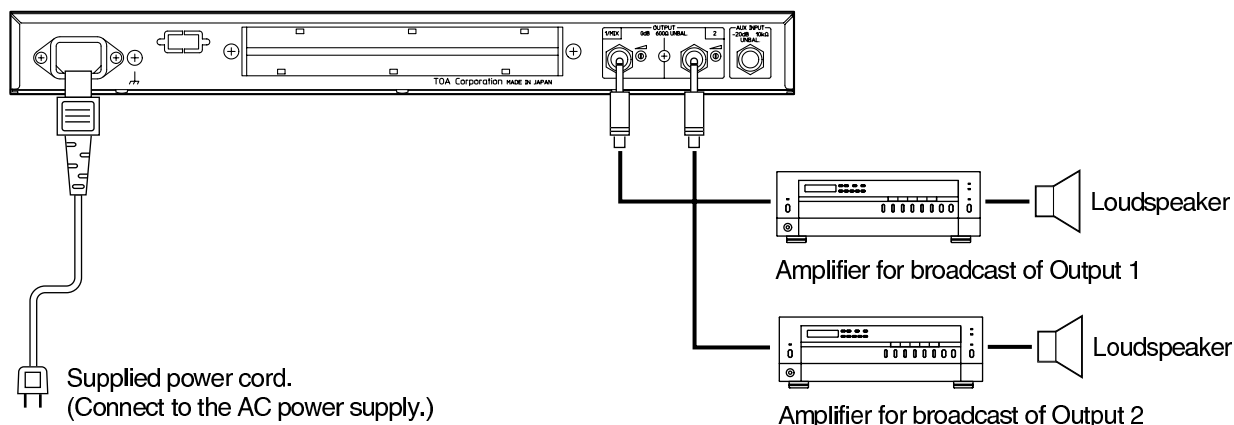

7.2.2. Playback method

Here, the method to play back programs already input will be explained.

Step 1. Check the unit for proper connection, then remove the front cover to insert the memory card.

- For about three seconds after inserting the card, the unit accesses the card to read data from it. Any key cannot be used during this period.
- Do not insert nor eject the card while the unit is accessing data, otherwise data in the card may be lost.

Step 2. Switch on the power of both the unit and amplifiers for broadcast, and set the amplifier's volume control to the minimum position.

Step 3. Playback operation starts. (Refer to the next page "Operation procedures.")

Step 4. Adjust the amplifier's volume control to the proper level.

7.2.3. Playback operating procedure
[Playback of the program set for output 1]

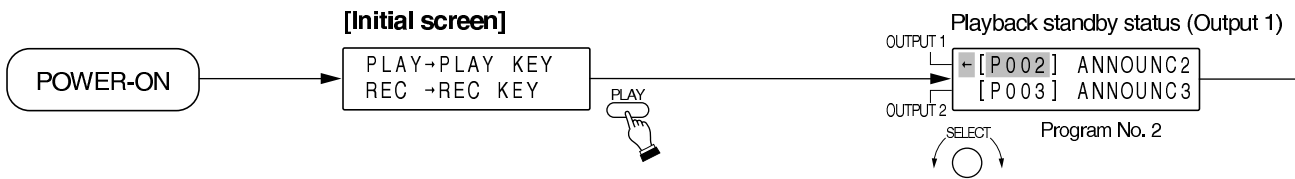

Step 1. Press the Playback key.

Step 2. Turn the Selection dial to select the program number.

Tips: The output volume level can be adjusted with the front panel-mounted operation key. (See p. 31 "Playback program information display.")

[Playback of the program set for output 2]

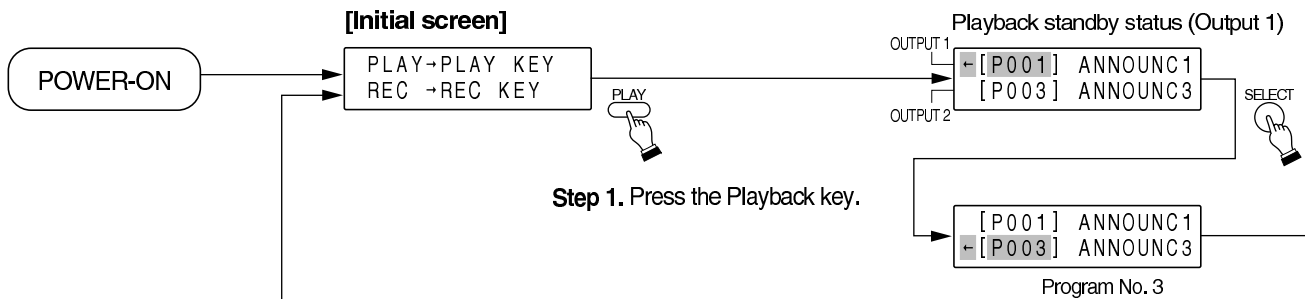

Step 1. Press the Playback key.

Step 2. Press the Selection dial to select the Output 2.

[Playback of the program set for outputs 1 and 2]

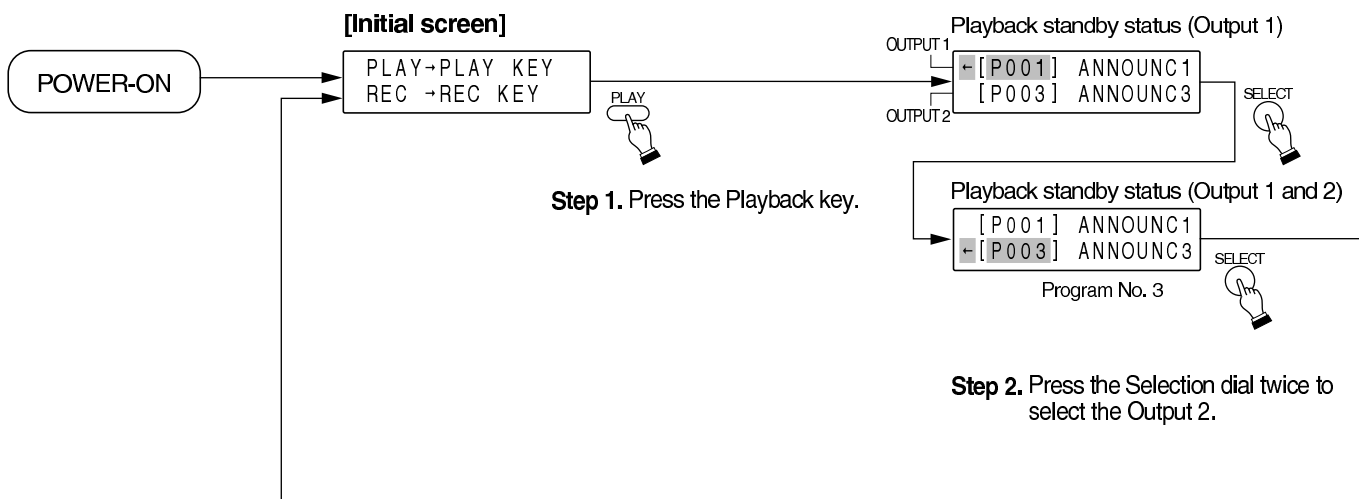

Step 1. Press the Playback key.

Step 2. Press the Selection dial twice to select the Output 2.

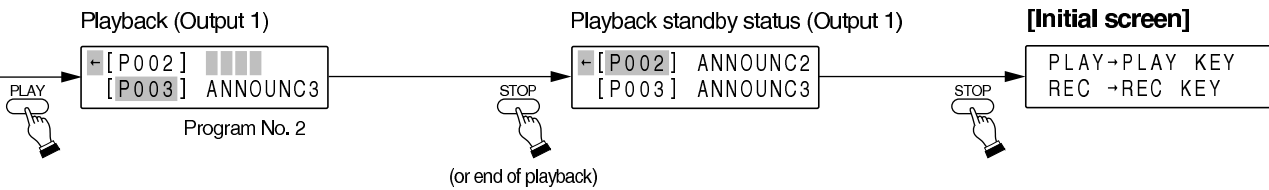

Step 3. Press the Playback key to begin playback.

Tips: The playback screen display can be changed. (See p. 30 "Screen display during playback.")
The output level setting can be changed. (See p. 31 "Playback program information display.")

Step 4. Press the Stop key to return to the playback standby mode. (Repeat Step 2. and 3. for continuous playback.)

Step 5. Press the Stop key to return to the initial screen.

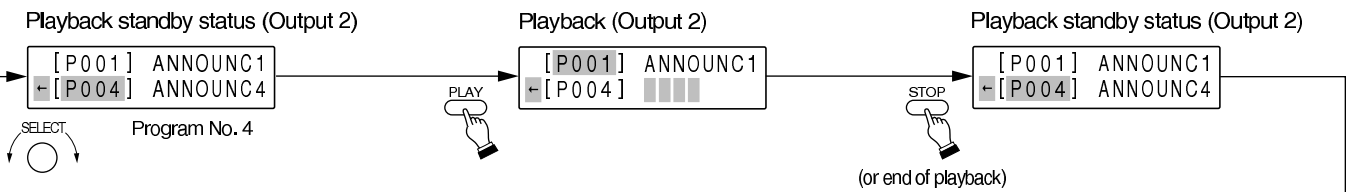

Step 3. Turn the Selection dial to select the program number.

Step 4. Press the Playback key to begin playback.

Step 5. Press the Stop key to return to the playback standby mode. (Repeat Step 3. and 4. for continuous playback.)

Step 6. Press the Stop key to return to the initial screen.

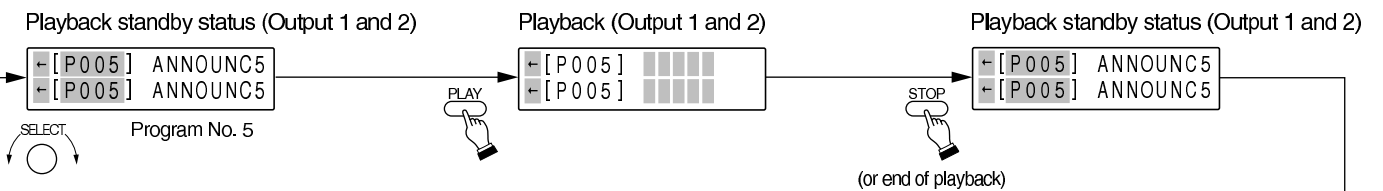

Step 3. Turn the Selection dial to select the program number.

Step 4. Press the Playback key to begin playback.

Step 5. Press the Stop key to return to the playback standby mode. (Repeat Step 3. and 4. for continuous playback.)

Step 6. Press the Stop key to return to the initial screen.

7.2.4. Screen display during playback

Display can be changed by turning the Selection Dial during playback. (This does not adversely affect the current playback output.)

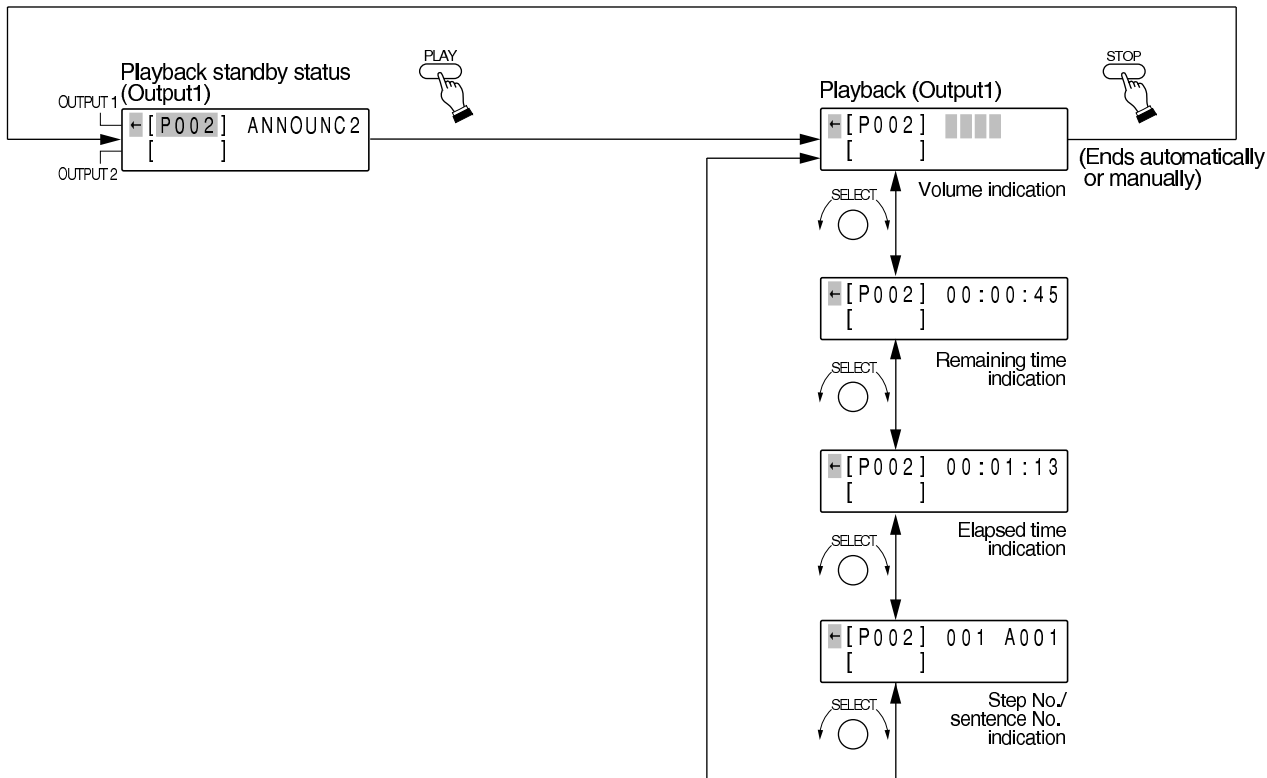

7.2.5. Playback program information diplay

Master volume settings can be changed while the unit is in playback standby mode or it is playing back.

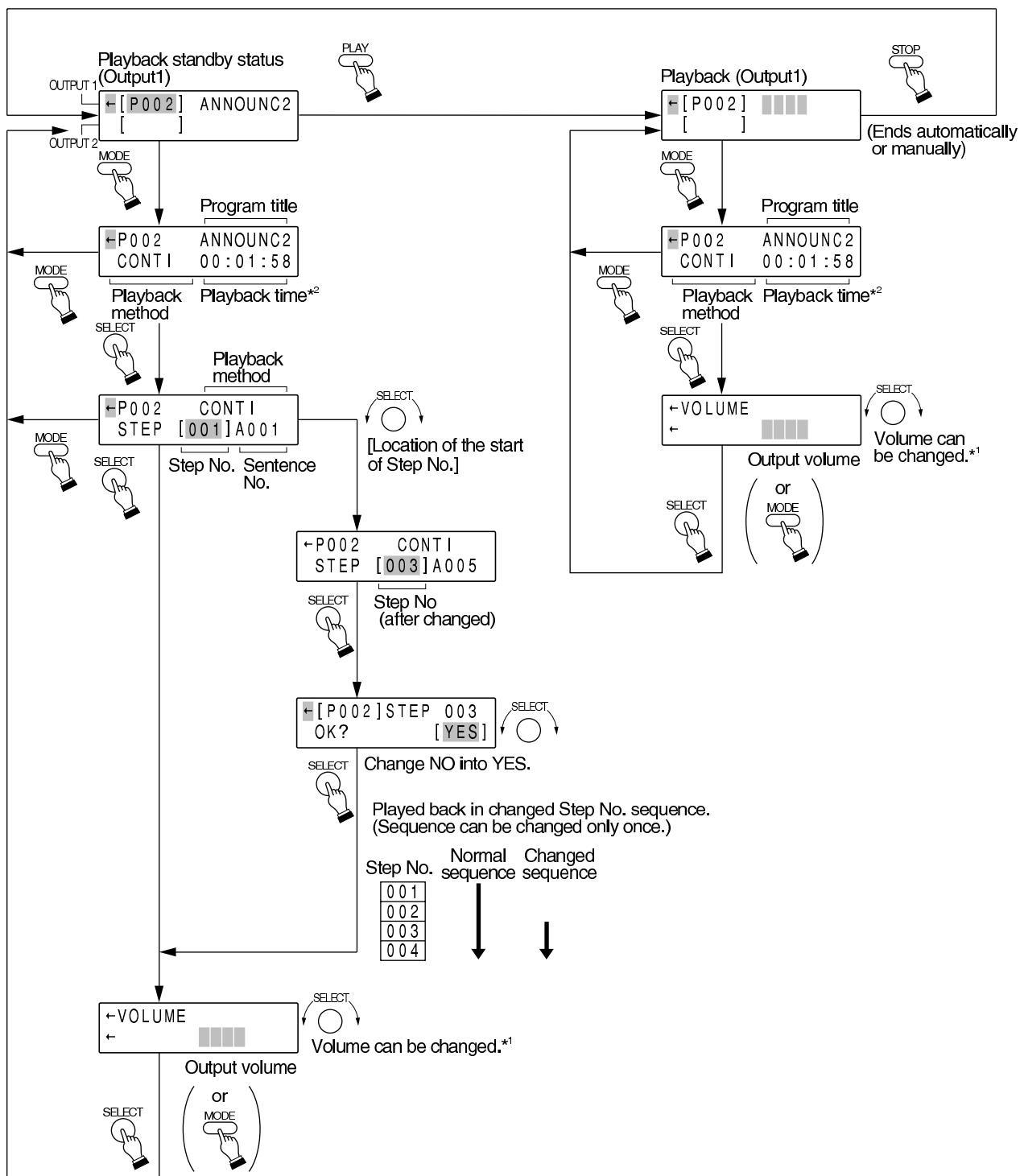

*1 Changing the volume here changes the setting made in "4-2 MASTER VOLUME" of the setting menu.

*2 The playback time is not displayed in Endless playback mode. The Step Number Locate function cannot be used, either.

7.3. Emergency Playback (External Activation)

By directly designating and activating a recorded emergency sentence, emergency playback can be achieved with no need to set programs. Even when the unit is in use for broadcast from the microphone or external equipment or it is playing back a program, the current broadcast is interrupted and the program playback stops, allowing the emergency broadcast to go through.

- The emergency sentence is played back from both Outputs 1 and 2.
During emergency playback, both busy outputs 1 and 2 are shorted.
- The emergency sentence is broadcast at the maximum sound volume. To adjust the emergency broadcast volume, use the output volume control located on the rear panel.
- Insert the card containing the emergency sentence into card slot A. The emergency sentence recorded on the slot B memory card can be played back only when the card is not inserted into slot A. Emergency playback cannot be accomplished when the card containing no emergency sentence is inserted into slot A. For recording the emergency sentence, refer to p. 21.

7.4. Playing Back the Emergency Sentence

The emergency sentence cannot be played back manually. Arrange the switch for emergency playback activation separately, and connect that switch to the emergency playback activation control input located on the rear panel. Shorting that switch activates the emergency playback.

To stop playback of the emergency sentence, press the front-mounted [STOP] key. (This function can not be achieved by remote control.)

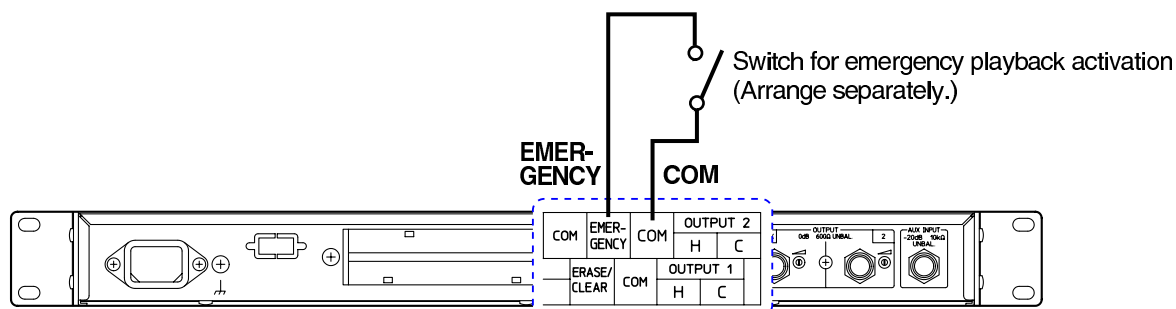

The emergency sentence is played back regardless of activation modes 1-7 set at menu "5-2 ACTIVATION MODE SELECTION."

- One-shot pulse input activation
The emergency sentence is played back once, and then stops.
- Level-operated input activation
The same emergency sentence is played back repeatedly as far as the emergency terminal is closed. When the emergency terminal is opened, playback stops after the remaining part of the emergency sentence is completed.

8. SETTING FUNCTIONS

8.1. Setting Functions (1. PROGRAM SETTING)

8.1.1. Program input setting (1-1 PROGRAM INPUT)

Refer to p. 54 for the operation procedures.

[Playback sound data section and Control data section]

Each of the programs (P001-P256) consists of the "Playback sound data section" and "Control data section," each of which is composed of input data.

Refer to p. 16 "THE SENTENCE AND PROGRAM" for details.

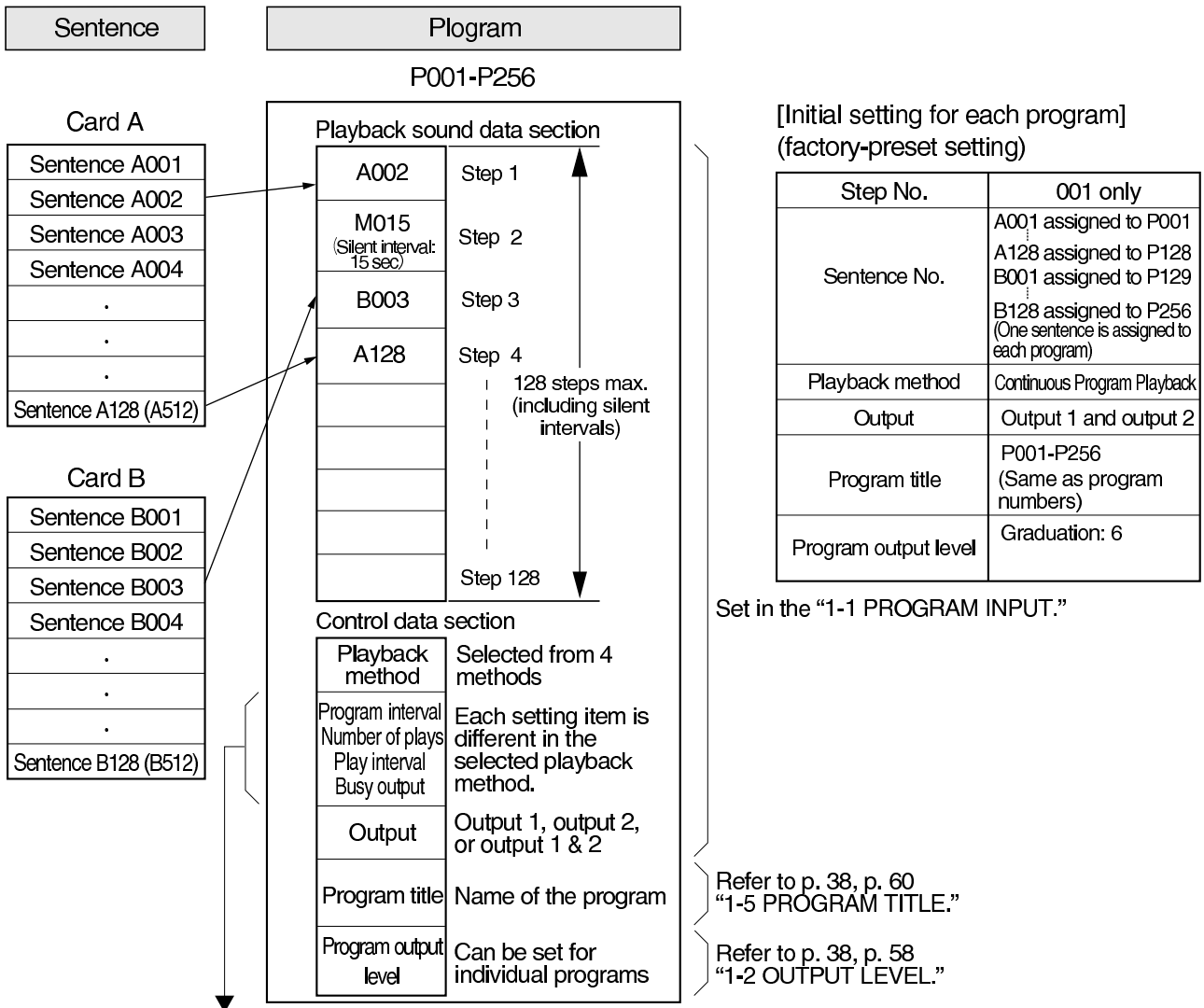

[Setting items different in playback methods]

Playback method	Program interval (Interval Timer)	Number of plays	Play interval	Busy output
Continous Program Playback	—	—	—	—
Single Program Playback	OFF (no relation) 10, 20, ...50 sec 1, 2, ...99 min	—	—	ON (At program interval) OFF (interval)
Repeat Playback	—	1, 2, ...128 repeats, Endress	0, 10, ...50 sec 1, 2, ...99 min	ON (At repeat interval) OFF (interval)
Endless Playback	—	—	0, 1, 2, 3, 4, 5 sec	—

8.1.2. Playback Method

There are 4 different playback methods. Select one of them when making the setting.

[Continuous program playback]

Sentences and silent intervals registered into the program are consecutively played back in order of step number, and playback stops after the program is completed. This method (factory-preset) is used for program playback unless other method is especially selected.

To stop playback manually, press the [STOP] key or short the Stop terminal.

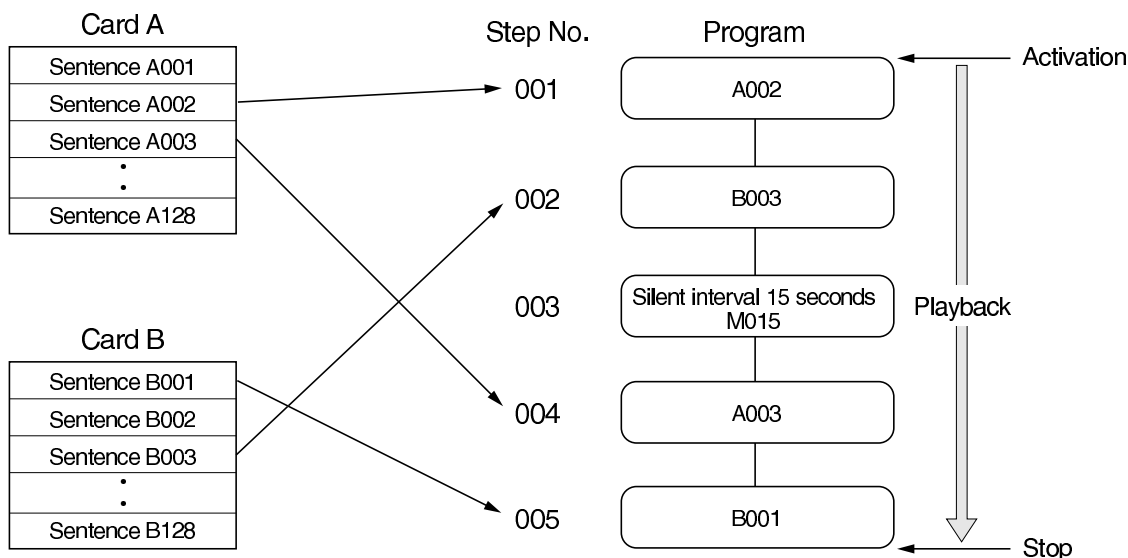

[Single-program playback]

One each of sentences silent intervals registered into the program is played back in order of step number each time the unit is activated. Playback automatically stops after a single sentence is completed. After the last sentence is completed, playback returns to the first step of the program with the next activation. Activating the unit in the Stop mode (initiated by either pressing the [STOP] key or shorting the Stop control terminals) begins playback from the next step number. In addition to manual playback and terminal-activated playback, it is also possible to automatically playback sentences with time intervals (program intervals) set between them using the unit's built-in timer (Interval Broadcast). Intervals of OFF, 10-50 seconds (in 10-second units), or 1-99 minutes (in 1-minute units) can be set.

To stop playback manually, press the [STOP] key or short the Stop terminal.

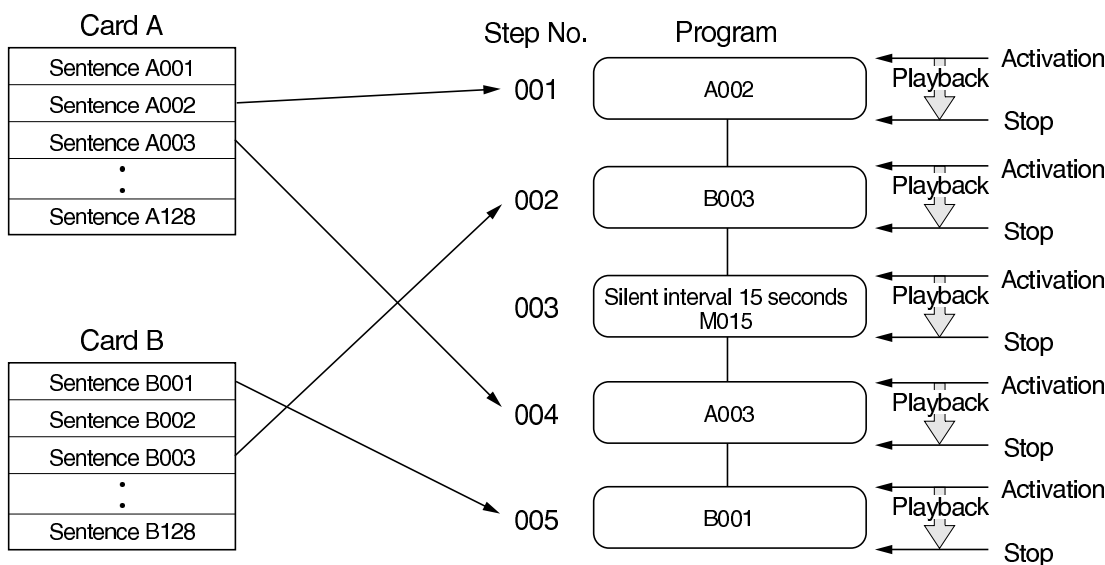

Playback begins with the first sentence (A002) when activated next time.

[Repeat playback]

Sentences and silent intervals registered into each program are repeatedly played back in order of step number at the preset repetition interval (i.e. the duration from the last sentence playback till the first sentence playback) and by the preset number of repetitions. When the program is played back for the set number of repetitions, the unit stops its operation and the initial screen is displayed. Intervals of 0-50 seconds (in 10-second unit) or 1-99 minutes (in 1-minute units) can be set. The number of repeats can be set for either "Endless" or 1 - 128 times.

To stop playback, press the [STOP] key or short the Stop terminal.

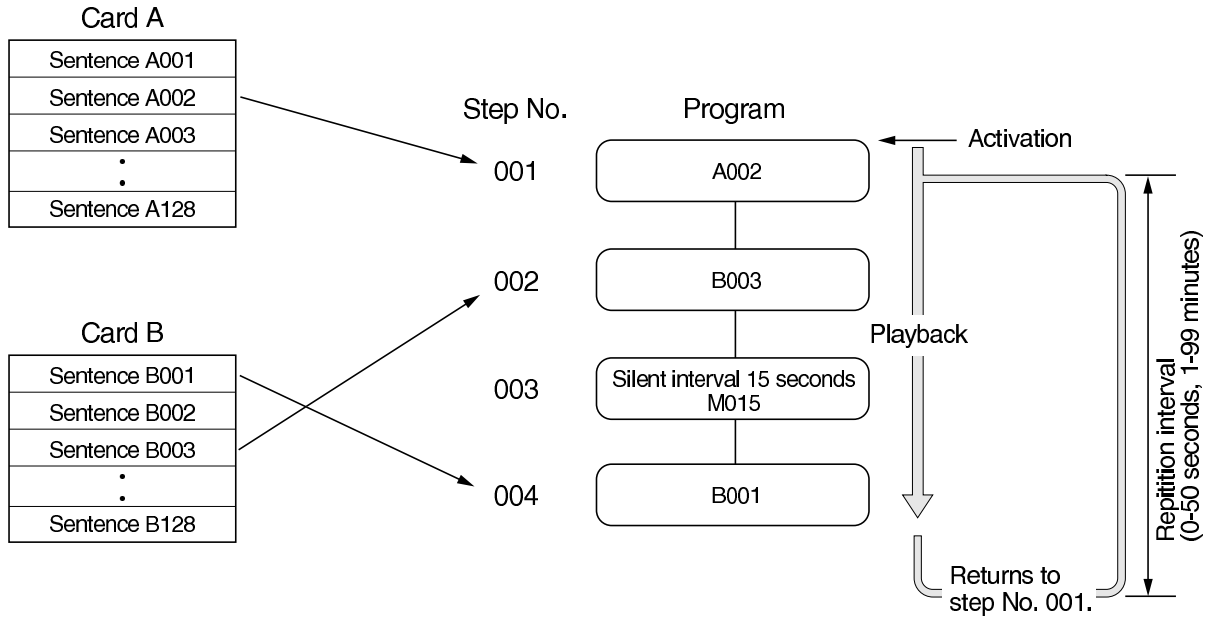

[Endless playback]

This function plays back all the sentences recorded on Card A, being followed by Card B in order of sentence number. After the last sentence is completed, playback returns to the first sentence and continues. Playback intervals of 0-5 seconds can be inserted between sentences.

To stop playback, press the [STOP] key or short the Stop terminal.

Example of the endless playback beginning with the sentence No. A001.

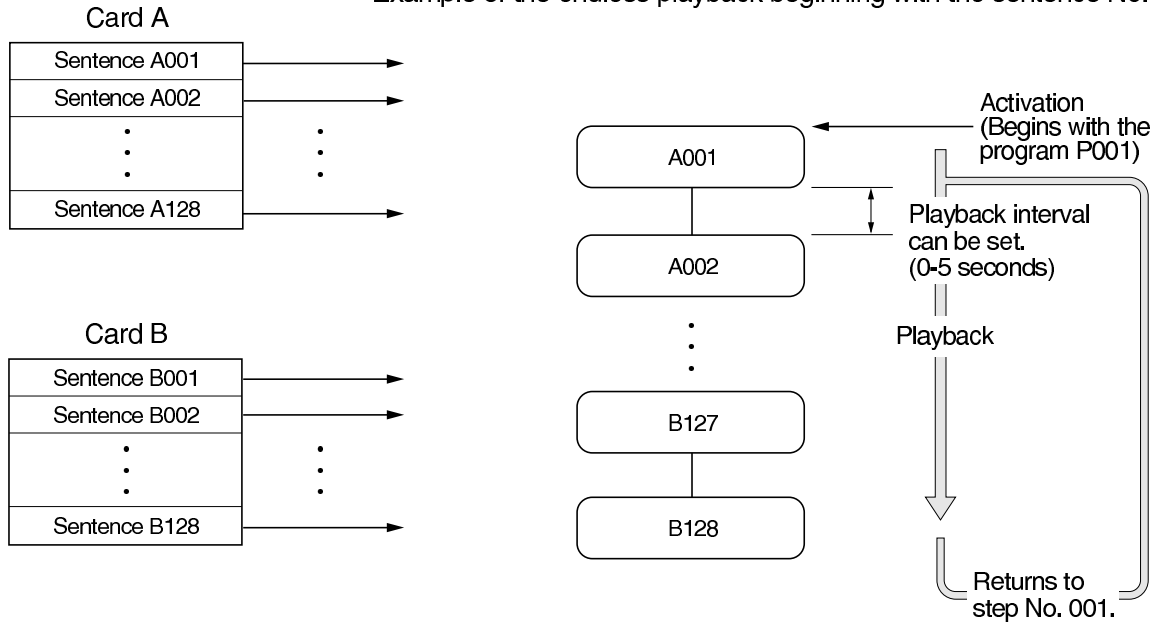

* Note that the playback method of program No. P001 should be preset for "Endless playback."

● Designating the beginning sentence for the endless playback

By selecting and playing back the program number (example: P002) set for the endless playback, the endless playback begins with the sentence (example: A002) corresponding to the program number. The relationship of the program number and sentence number is shown below.

Each of other program numbers (except No.P002 in this example) than designated as endless method can be freely set for the playback method.

Program No. set for "Endless playback"	Beginning Sentence No.
P001	→ A001
P002 (The example shown here)	→ A002 (The example shown here)
⋮	⋮
P128	→ A128
P129	→ B001
⋮	⋮
P256	→ B128

8.1.3. Step input, evasare and insertion

[Step input]

Example when the Sentence No. A003 is input in the Step No.002

Example when the Sentence No. A003 is input in the Step No. 002

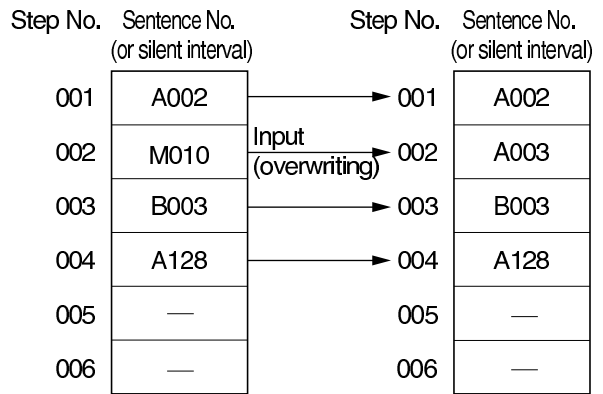

[Erasing the steps]

As steps are erased, the sentence automatically shrinks to close the remaining gaps, and changes the step numbers accordingly.

When Step No. 002 is erased

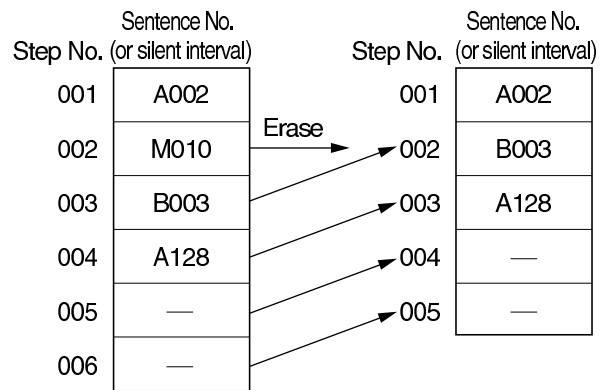

[Inserting the steps]

As steps are inserted, the sentence expands to include the new steps in their designated positions, and changes the step numbers accordingly.

When sentence No. B003 is inserted into Step No. 002

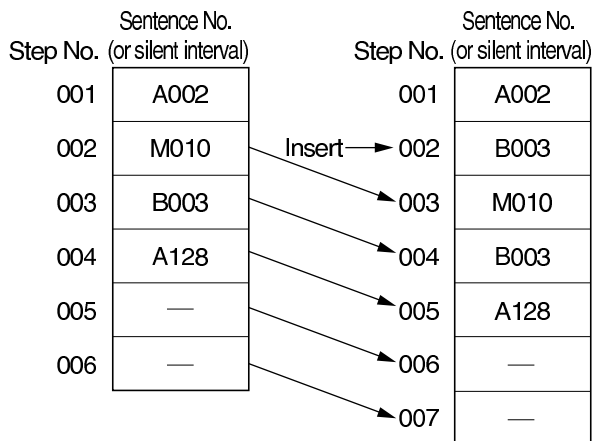

8.1.4. Setting the program output level (1-2 OUTPUT LEVEL)

Output levels can be set for each created program.
Refer to p. 58 for the operation procedures.

8.1.5. Program verification (1-3 PROGRAM VERIFICATION)

You can verify the program title, playback method, and content of the created program.
Refer to p. 58 for the operation procedures.

8.1.6. Program initialization (1-4 PROGRAM INTIALIZATION)

Created programs can be initialized by designating the program number. Initializing a program erases the whole content of that program, and returns its setting to the initial value. (Refer to p. 33.) You cannot initialize all programs at a time.
Refer to p. 60 for the operation procedures.

8.1.7. Entering and editing the program title (1-5 PROGRAM TITLE)

You can assign the title to the created program or modify the registered title.
Refer to p. 60 for the operation procedures.

8.2. Setting Functions (2. EDITING THE SENTENCES)

It is possible to verify the content of the recorded sentence, erase the sentence, and set the title of the sentence. Be sure to execute optimization of the card (p. 49, 76) after erasing the sentence.

8.2.1. Verifying the sentence (2-1 SENTENCE VERIFICATION)

You can verify the recording sound quality, title, and recording time of the recorded sentence.
Refer to p. 62 for the operation procedures.

8.2.2. Erasing the sentence (2-2 SENTENCE ERASURE)

You can erase the recorded sentence by designating the desired sentence. When erasing, the entire sentence must be erased. It is impossible to erase a part of the sentence or multiple sentences at a time.
Be sure to execute optimization of the card (p. 49, 76) after erasing the sentence.
Refer to p. 62 for the operation procedures.

8.2.3. Entering and editing the sentence title (2-3 SENTENCE TITLE)

You can assign the title to the recorded sentence or modify the registered title.
There are two different methods to enter the sentence title: one to enter from recording mode, and one to enter at the menu 2-3 Sentence Title. Refer to p. 22 for how to enter from recording mode.
Refer to p. 64 for the operation procedures.

8.2.4. Erasing the silent areas (2-4 INTERVAL ERASING)

Silent areas that remain before and after the recorded content after recording can be erased in the range of 0-9.9 second (in 0.1-second units). After erasing the silent areas, be sure to monitor the content and register the erasure setting.
Refer to p. 64 for the operation procedures.

Note

Sounds can be played back only at the headphone output, and not at Output 1 or Output 2.

8.3. Setting Functions (3. MONITORING THE SENTENCES AND PROGRAMS)

You can monitor recorded sentences or created programs with a headphone.

Note: Sounds can be played back only at the headphone output, and not at Output 1 or Output 2.

8.3.1. Monitoring the sentence (3-1 SENTENCE MONITORING)

Recorded sentences can be monitored with a headphone.

Refer to p. 66 for the operation procedures.

Caution: Pressing the [PLAY] key causes the unit to switch to playback mode, disabling the monitoring function.

8.3.2. Monitoring the program (3-2 PROGRAM MONITORING)

Created programs can be monitored with a headphone.

Refer to p. 66 for the operation procedures.

Caution: Pressing the [PLAY] key causes the unit to switch to playback mode, disabling the monitoring function.

8.4. Setting Functions (4. OUTPUT/VOLUME SETTING)

8.4.1. Selecting single- or dual-source playback mode (4-1 DUAL-SOURCE PLAYBACK SELECTION)

Set the program playback for either single-source output or dual-source output.

[Single-source playback mode]

Individual output settings for each program are ignored, and broadcast is always made only from Output 1. Output 2 cannot be used. If you simultaneously play back the program set for Output 1 and the program set for Output 2, both programs are mixed and broadcast from Output 1.

[Dual-source playback mode]

Programs are broadcast from Output 1 and Output 2 depending on the setting.

Refer to p. 67 for the operation procedures.

Note: The unit is factory-preset for dual-source playback mode.

8.4.2. Master volume setting (4-2 MASTER VOLUME)

Set the overall volume level of program playback. Although the output volume level individually set for each program is effective as the relative sound volume between programs, the absolute sound volume is determined here. Note that you cannot preset the volume for the microphone input or auxiliary input. To adjust the volume of these inputs, use the corresponding volume controls on the front panel.

Refer to p. 67 for the operation procedures.

Note: The volume is factory-preset for [8].

8.5. Setting Functions (5. OPERATION SETTING)

8.5.1. Remote control (5-1 CONTROL FUNCTION SETTING) [Recording/erasure, playback and stop]

Using the control input terminals located on the rear panel, sentence recording and erasure, as well as program playback can be remotely controlled by external equipment. It is possible to remotely play back and stop the program set for Output 1 separately from the program set for Output 2.

Refer to p.68 for the operation procedures.

[Direct mode and binary mode]

Short the activation control input terminals when selecting the sentence number in remote recording and remote erasure, and when selecting the program number in remote playback. Two different modes, direct mode and binary mode, are made available as the method (control function) to select the sentence and program numbers by means of the activation control terminals.

Note: The unit is factory-preset for direct mode.

[Activation control inputs 1-8 in direct mode]

Activation control terminal	Recording /Erasure	Playback
	Sentence No.	Program No.
1	A001	P001
2	A002	P002
3	A003	P003
4	A004	P004
5	A005	P005
6	A006	P006
7	A007	P007
8	A008	P008

[Activation control inputs 1-8 in binary mode]

Activation control terminal								Rec/ Erasure	Play	Activation control terminal								Rec/ Erasure	Play	Activation control terminal								Rec/ Erasure	Play										
1	2	3	4	5	6	7	8	Sentence No.	Program No.	1	2	3	4	5	6	7	8	Sentence No.	Program No.	1	2	3	4	5	6	7	8	Sentence No.	Program No.	1	2	3	4	5	6	7	8	Sentence No.	Program No.
00000000	A001	P001	00000010	A065	P065	00000001	B001	P129	00000011	B065	P193																												
10000000	A002	P002	10000010	A066	P066	10000001	B002	P130	10000011	B066	P194																												
01000000	A003	P003	01000010	A067	P067	01000001	B003	P131	01000011	B067	P195																												
11000000	A004	P004	11000010	A068	P068	11000001	B004	P132	11000011	B068	P196																												
00100000	A005	P005	00100010	A069	P069	00100001	B005	P133	00100011	B069	P197																												
10100000	A006	P006	10100010	A070	P070	10100001	B006	P134	10100011	B070	P198																												
01100000	A007	P007	01100010	A071	P071	01100001	B007	P135	01100011	B071	P199																												
11100000	A008	P008	11100010	A072	P072	11100001	B008	P136	11100011	B072	P200																												
00010000	A009	P009	00010010	A073	P073	00010001	B009	P137	00010011	B073	P201																												
10010000	A010	P010	10010010	A074	P074	10010001	B010	P138	10010011	B074	P202																												
01010000	A011	P011	01010010	A075	P075	01010001	B011	P139	01010011	B075	P203																												
11010000	A012	P012	11010010	A076	P076	11010001	B012	P140	11010011	B076	P204																												
00110000	A013	P013	00110010	A077	P077	00110001	B013	P141	00110011	B077	P205																												
10110000	A014	P014	10110010	A078	P078	10110001	B014	P142	10110011	B078	P206																												
01110000	A015	P015	01110010	A079	P079	01110001	B015	P143	01110011	B079	P207																												
11110000	A016	P016	11110010	A080	P080	11110001	B016	P144	11110011	B080	P208																												
00001000	A017	P017	00001010	A081	P081	00001001	B017	P145	00001011	B081	P209																												
10001000	A018	P018	10001010	A082	P082	10001001	B018	P146	10001011	B082	P210																												
01001000	A019	P019	01001010	A083	P083	01001001	B019	P147	01001011	B083	P211																												
11001000	A020	P020	11001010	A084	P084	11001001	B020	P148	11001011	B084	P212																												
00101000	A021	P021	00101010	A085	P085	00101001	B021	P149	00101011	B085	P213																												
10101000	A022	P022	10101010	A086	P086	10101001	B022	P150	10101011	B086	P214																												
01101000	A023	P023	01101010	A087	P087	01101001	B023	P151	01101011	B087	P215																												
11101000	A024	P024	11101010	A088	P088	11101001	B024	P152	11101011	B088	P216																												
00011000	A025	P025	00011010	A089	P089	00011001	B025	P153	00011011	B089	P217																												
10011000	A026	P026	10011010	A090	P090	10011001	B026	P154	10011011	B090	P218																												
01011000	A027	P027	01011010	A091	P091	01011001	B027	P155	01011011	B091	P219																												
11011000	A028	P028	11011010	A092	P092	11011001	B028	P156	11011011	B092	P220																												
00111000	A029	P029	00111010	A093	P093	00111001	B029	P157	00111011	B093	P221																												
10111000	A030	P030	10111010	A094	P094	10111001	B030	P158	10111011	B094	P222																												
01111000	A031	P031	01111010	A095	P095	01111001	B031	P159	01111011	B095	P223																												
11111000	A032	P032	11111010	A096	P096	11111001	B032	P160	11111011	B096	P224																												
00000100	A033	P033	00000110	A097	P097	00000101	B033	P161	00000111	B097	P225																												
10000100	A034	P034	10000110	A098	P098	10000101	B034	P162	10000111	B098	P226																												
01000100	A035	P035	01000110	A099	P099	01000101	B035	P163	01000111	B099	P227																												
11000100	A036	P036	11000110	A100	P100	11000101	B036	P164	11000111	B100	P228																												
00100100	A037	P037	00100110	A101	P101	00100101	B037	P165	00100111	B101	P229																												
10100100	A038	P038	10100110	A102	P102	10100101	B038	P166	10100111	B102	P230																												
01100100	A039	P039	01100110	A103	P103	01100101	B039	P167	01100111	B103	P231																												
11100100	A040	P040	11100110	A104	P104	11100101	B040	P168	11100111	B104	P232																												
00010100	A041	P041	00010110	A105	P105	00010101	B041	P169	00010111	B105	P233																												
10010100	A042	P042	10010110	A106	P106	10010101	B042	P170	10010111	B106	P234																												
01010100	A043	P043	01010110	A107	P107	01010101	B043	P171	01010111	B107	P235																												
11010100	A044	P044	11010110	A108	P108	11010101	B044	P172	11010111	B108	P236																												
00110100	A045	P045	00110110	A109	P109	00110101	B045	P173	00110111	B109	P237																												
10110100	A046	P046	10110110	A110	P110	10110101	B046	P174	10110111	B110	P238																												
01110100	A047	P047	01110110	A111	P111	01110101	B047	P175	01110111	B111	P239																												
11110100	A048	P048	11110110	A112	P112	11110101	B048	P176	11110111	B112	P240																												
00001100	A049	P049	00001110	A113	P113	00001101	B049	P177	00001111	B113	P241																												
10001100	A050	P050	10001110	A114	P114	10001101	B050	P178	10001111	B114	P242																												
01001100	A051	P051	01001110	A115	P115	01001101	B051	P179	01001111	B115	P243																												
11001100	A052	P052	11001110	A116	P116	11001101	B052	P180	11001111	B116	P244																												
00101100	A053	P053	00101110	A117	P117	00101101	B053	P181	00101111	B117	P245																												
10101100	A054	P054	10101110	A118	P118	10101101	B054	P182	10101111	B118	P246																												
01101100	A055	P055	01101110	A119	P119	01101101	B055	P183	01101111	B119	P247																												
11101100	A056	P056	11101110	A120	P120	11101101	B056	P184	11101111	B120	P248																												
00011100	A057	P057	00011110	A121	P121	00011101	B057	P185	00011111	B121	P249																												
10011100	A058	P058	10011110	A122	P122	10011101	B058	P186	10011111	B122	P250																												
01011100	A059	P059	01011110	A123	P123	01011101	B059	P187	01011111	B123	P251																												
11011100	A060	P060	11011110	A124	P124	11011101	B060	P188	11011111	B124	P252																												
00111100	A061	P061	00111110	A125	P125	00111101	B061	P189	00111111	B125	P253																												
10111100	A062	P062	10111110	A126	P126	10111101	B062	P190	10111111	B126	P254																												
01111100	A063	P063	01111110	A127	P127	01111101	B063	P191	01111111	B127	P255																												
11111100	A064	P064	11111110	A128	P128	11111101	B064	P192	11111111	B128	P256																												

Note: [1] in the table stands for "make".

8.5.2. Activation mode for remote control (5-2 ACTIVATION MODE SELECTION)

Activation mode can be set individually for remote recording, remote playback, and remote stop. Refer to p. 68 for the operation procedures.

[Remote recording]

- (1) Recording activation mode 1 (one-shot pulse input activation)*
- (2) Recording activation mode 2 (level-operated input activation)

[Remote playback]

- Direct mode
 - (1) Playback Activation Mode 1 (one-shot pulse input activation, last-in rejected priority)*
 - (2) Playback Activation Mode 2 (one-shot pulse input activation, last-in-first-out priority)
 - (3) Playback Activation Mode 3 (one-shot pulse input activation, smaller program number priority)
 - (4) Playback Activation Mode 4 (one-shot pulse input activation, sequential storage/playback)
 - (5) Playback Activation Mode 5 (level-operated input activation, first-in-first-out priority)
 - (6) Playback Activation Mode 6 (level-operated input activation, last-in-first-out priority)
 - (7) Playback Activation Mode 7 (level-operated input activation, smaller program number priority)
- Binary mode
 - (1) Playback Activation Mode 1 (one-shot pulse input activation, last-in rejected priority)
 - (2) Playback Activation Mode 2 (one-shot pulse input activation, last-in-first-out priority)
 - (3) Playback Activation Mode 3 (one-shot pulse input activation, smaller program number priority)
 - (4) Playback Activation Mode 4 (one-shot pulse input activation, sequential storage/playback)
 - (5) Playback Activation Mode 5 (level-operated input activation)

[Remote stop]

- (1) Stop Activation Mode 1 (stop during playback)*
- (2) Stop Activation Mode 2 (stop after sentence playback completion)

* : Factory-preset mode

8.5.3. Direct mode

[Remote recording]

Sentences cannot be recorded over previously-recorded sentences. Be sure the previous recording is erased before re-recording. Up to eight sentences (A001-A008) can be remotely recorded on the Slot A memory card. Note that the Slot B memory card cannot be used for remote recording. Recording begins by shorting the Activation Control input after the Recording Control input is shorted.

- (1) Recording Activation Mode 1 (one-shot pulse input activation) Recording Control input ON OFF

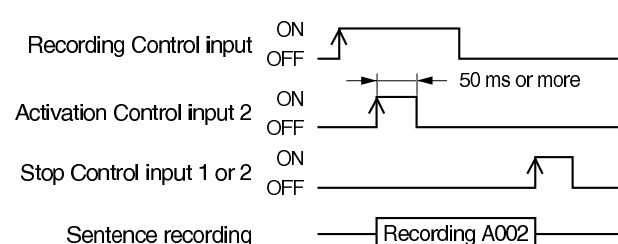

- To start recording, first short the Recording Control input (OFF → ON), then the Activation Control input.
- To stop recording, press the [STOP] key or short Stop Control Input 1 or 2.
- Recording automatically stops when the remaining recording time reaches 0.
- Playback cannot be activated during recording.

- (2) Recording Activation Mode 2 (level-operated input activation) Recording Control input On

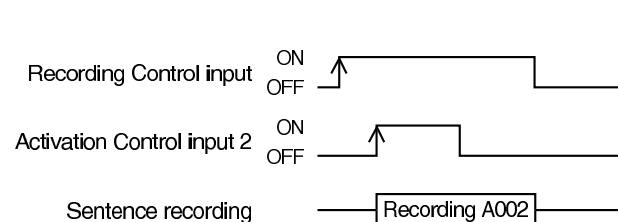

- Recording begins when the activation control input is closed following the recording control input, and continues while the recording control input remains closed.
- Recording automatically stops when the remaining recording time reaches 0.
- Recording stops when the Stop key is pressed and either the Stop Control Input 1 or 2 is closed.
- Playback cannot be activated during recording.

[Remote erasure]

To erase recording, short the Erasure Control input, then the Activation Control input. Erasure stops following completion.

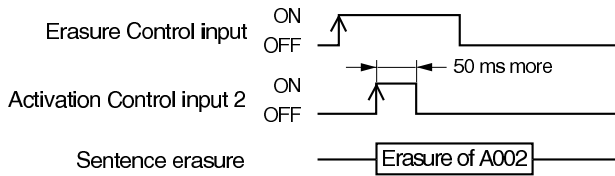

- All front panel keys are disabled during erasure.

[Remote playback]

Up to eight programs (P001-P008) can be remotely played back. Shorting the Activation Control input enables playback.

Note: This assumes that program Nos. P001 and P002 are set for Output 1.

(1) Playback Activation Mode 1 (one-shot pulse input activation, last-in rejected priority)

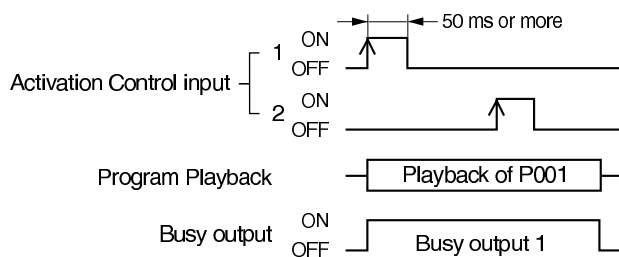

- Playback begins when the Activation Control input is shorted (OFF → ON).
- Any further inputs to the currently-engaged Activation Control input are rejected.
- Programs are played back only once, even if the Activation Control input remains shorted.
- When multiple Activation Control inputs are simultaneously shorted, the program with the smallest number is played back.

(2) Playback Activation Mode 2 (one-shot activation, last-in-first-out priority)

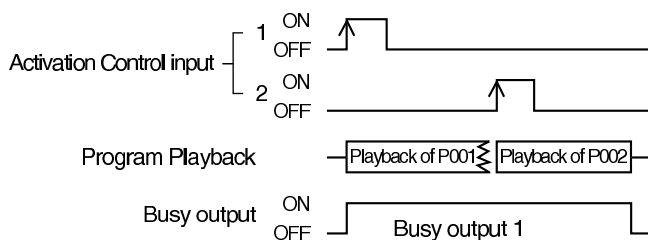

- Playback begins when the activation control input is shorted.
- The most recent Activation Control input takes precedence.
- Programs are played back only once, even if the Activation Control input remains shorted.

(3) Playback Activation Mode 3 (one-shot pulse input activation, small number program priority)

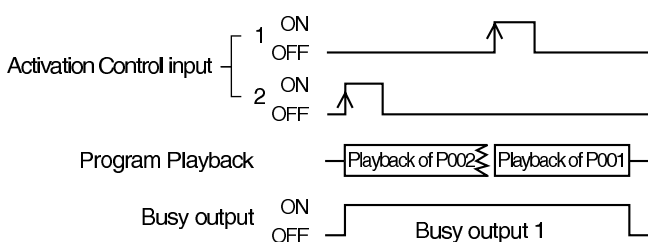

- Playback begins when the activation control input is shorted.
- If the Activation Control input has a smaller program number than that of the currently playing program, the program with the smaller number is played back. The input with the larger program number is rejected.
- Programs are played back only once, even if the Activation Control input remains shorted.

(4) Playback Activation Mode 4 (one-shot activation, sequential storage and playback)

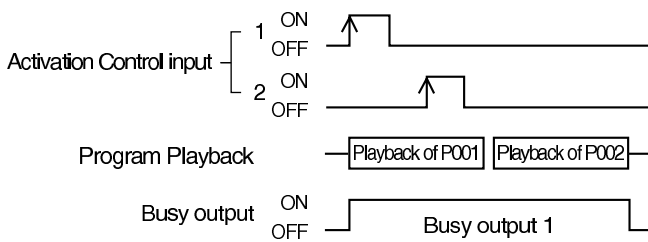

- Playback begins when the Activation Control input is shorted.
- All subsequent Activation Control inputs are sequentially stored and programs are played back in input order.
- Up to 16 inputs are stored for each output.
- When simultaneous Activation Control inputs are received, the program with the smallest program number is played back.
- Programs are played back only once, even if the Activation Control input remains shorted.
- Shorting the Stop Control input stops the program being played back. (If the Stop 1 Control input is shorted when the program is played back from both Outputs 1 and 2, playback from Output 1 stops. However, Output 2 continues to play back the program.) If another control input has been stored, the unit automatically begins to play back the stored program.
- If you short the Erase/Clear Control input while shorting the Playback Control input, all stored inputs are cleared.

(5) Playback Activation Mode 5 (level-operated input activation, first-in-first-out priority)

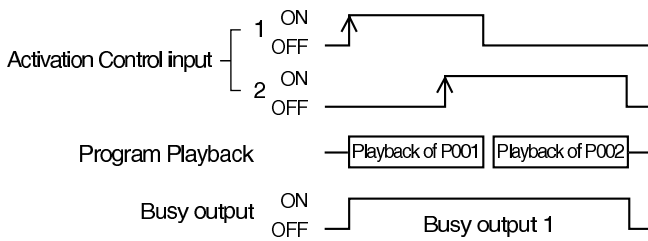

- Playback continues while the Activation Control input is shorted.
- All subsequent Activation Control inputs are rejected during playback.
- Subsequent Activation Control inputs during playback are stored and played back as soon as the current playback is completed.
- When multiple Activation Control inputs are simultaneously shorted, the program with the smallest program number is played back.

(6) Playback Activation Mode 6 (level-operated input activation, last-in-first-out priority)

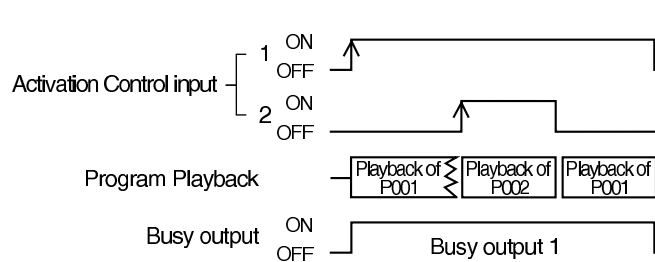

- Playback continues while the Activation Control input is shorted.
- The most recent Activation Control input takes precedence even during playback.
- During playback, other Activation Control inputs are stored and played back upon completion of the current playback.
- When simultaneous Activation Control inputs are received, the program with the smallest program number is played back.
- Playback continues while the Activation Control input is shorted.

(7) Playback Activation Mode 7 (level-operated input activation, chronological priority)

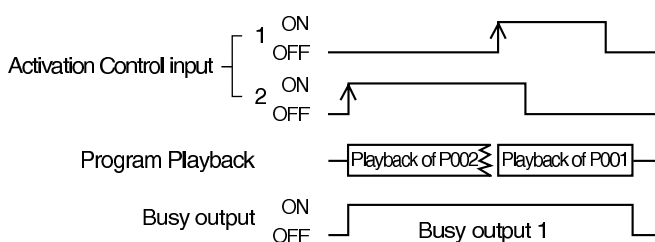

- If the input to the Activation Control input has a smaller program number than that of the currently playing program, the program with the smaller number is played back. The input with the larger program number is rejected.
- When simultaneous Activation Control inputs are received, the program with the smallest program number is played back.

[Remote stop]

You can set Stop mode when in one-shot-pulse-activated Playback Activation Mode (Playback Activation Mode 1-4).

(1) Stop Activation Mode 1 (stop during playback)

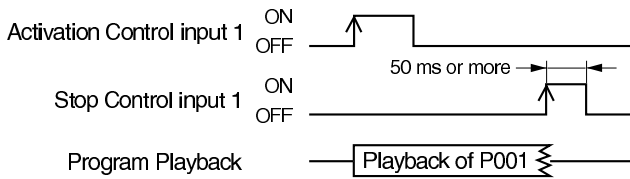

- Playback stops immediately after the Stop Control input is shorted (OFF → ON).
- Programs cannot be played back while the Stop Control input is shorted.

(2) Stop Activation Mode 2 (stop after sentence playback completion)

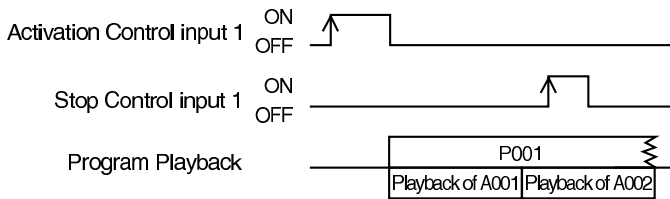

- Shorting the Stop Control input stops playback after the sentences in the currently playing program are completed.
- Programs cannot be played back while the Stop Control input is shorted.

8.5.4. Binary Mode

[Remote recording]

Sentences cannot be re-recorded over previously-recorded sentences. Be sure the previous recording is erased before re-recording. Up to 256 sentences (A001-A128 and B001-B128) can be remotely recorded. Sentences A001-128 are recorded on the Slot A memory card, and sentences B001-B128 on the Slot memory card. To start recording, short the Recording Control input after the Activation Control input is shorted.

(1) Recording Activation Mode 1 (one-shot pulse input activation)

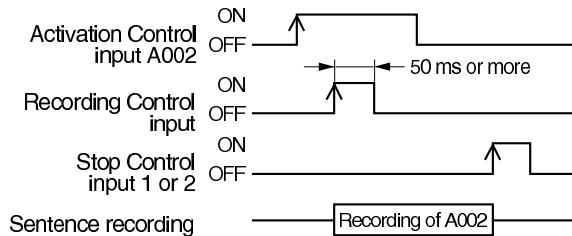

- Recording begins by shorting the Activation Control input (OFF → ON), then the Recording Control input.
- To stop recording, press the [STOP] key or short the Stop Control input 1 or 2.
- Recording automatically stops when the remaining recording time reaches 0.
- Playback cannot be activated during recording.

(2) Recording Activation Mode 2 (level-operated input activation)

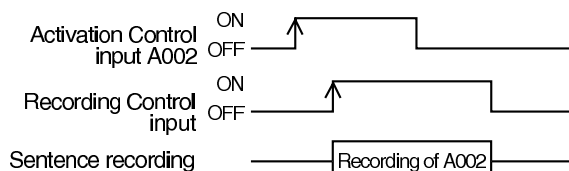

- Recording begins by shorting the Activation Control input, then the Recording Control input. Recording continues while the activation control input is shorted.
- Recording automatically stops when the remaining recording time reaches 0.
- Recording is terminated when the Stop key is pressed and either the Stop Control Input 1 or 2 is closed.
- Playback cannot be activated during recording.

[Remote erasure]

Recording can be erased by shorting the Erasure Control input after the Activation Control input is shorted. Erasure stops following completion.

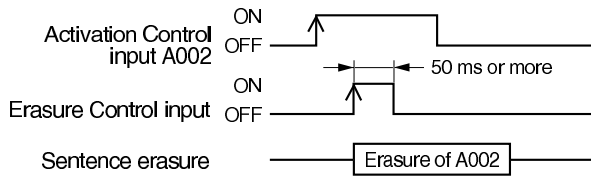

- All control inputs and front-panel keys are disabled during erasure.

[Remote playback]

Up to 256 programs (P001-P256) can be remotely played back by shorting the Playback Control input after the Activation Control input is shorted.

Note: This assumes that program Nos. P002 and P003 are set for Output 1.

(1) Playback Activation Mode 1 (one-shot pulse input activation, last-in rejected priority)

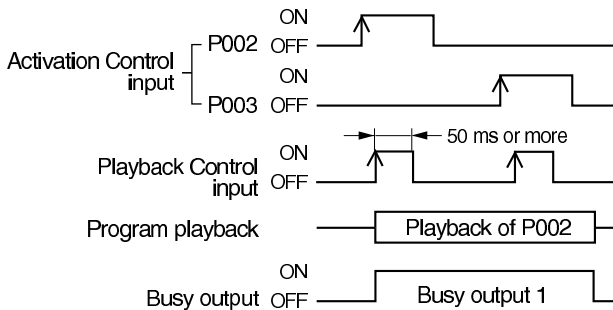

- Playback begins by shorting the Playback Control input after the Activation Control input is shorted (OFF → ON).
- The Activation Control input changed and re-activated during playback is rejected.
- Programs are played back only once, even if the Activation Control input remains shorted.

(2) Playback Activation Mode 2 (one-shot pulse input activation, last-in-first-out priority)

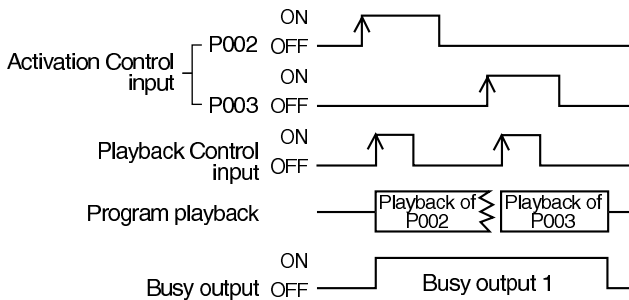

- Playback begins by shorting the playback control input after the Activation Control input is shorted (OFF → ON).
- Priority is given to the most recent Activation Control input and Playback Control input.
- Programs are played back only once, even if the Activation Control input remains shorted.

(3) Playback Activation Mode 3 (one-shot pulse input activation, small program number priority)

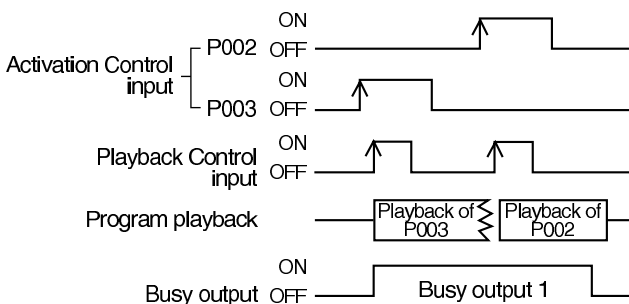

- Playback begins by shorting the Playback Control input after the Activation Control input is shorted (OFF → ON).
- If the Activation Control input and Playback Control input have a smaller program number than that of the currently playing program, the program with a smaller number is played back. The input with the larger program number is rejected.
- Programs are played back only once, even if the Activation Control input remains shorted.

(4) Playback Activation Mode 4 (one-shot pulse input activation, sequential storage/playback)

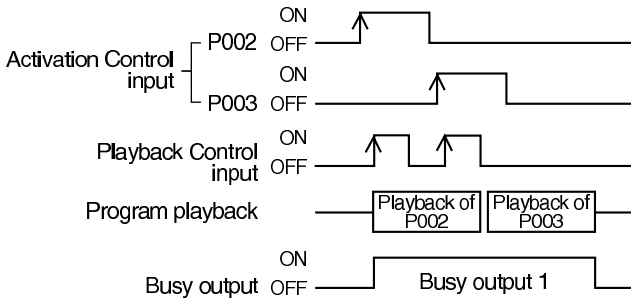

- Playback begins by shorting the Playback Control input after the Activation Control input is shorted (ON → OFF).
- All subsequent Activation Control inputs and Playback Control inputs are sequentially stored and played back in input order.
- Up to 16 inputs are stored for each output.
- Programs are played back only once, even if the Activation Control input remains shorted.
- Shorting the Stop Control input stops the program being played back. (If the Stop 1 Control input is shorted when the program is played back from both Outputs 1 and 2, playback from Output 1 stops. However, Output 2 continues to play back the program.) If another control input has been stored, the unit automatically begins to play back the stored program.
- If you short the Erase/Clear Control input while shorting the Playback Control input, all stored inputs are cleared.

(5) Playback Activation Mode 5 (level-operated input activation)

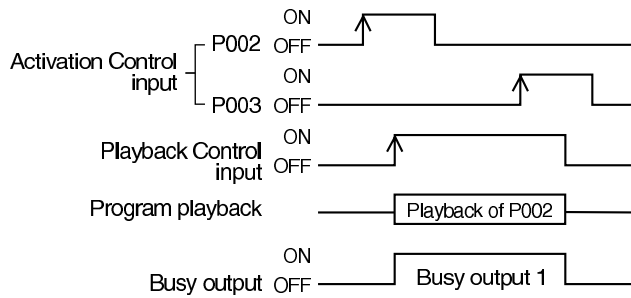

- Playback continues while the Playback Control input is shorted after the Activation Control input is shorted (OFF → ON).

[Remote stop]

It is possible to set Stop mode when in one-shot-pulse-activated Playback Activation Mode (Playback Activation Mode 1-4).

(1) Stop Activation Mode 1 (stop during playback)

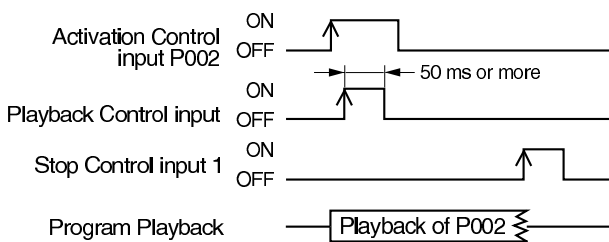

- Playback stops immediately after the Stop Control input is shorted (OFF → ON)
- Programs cannot be played back while the Stop Control input is shorted.

(2) Stop Activation Mode 2 (stop after sentence playback completion)

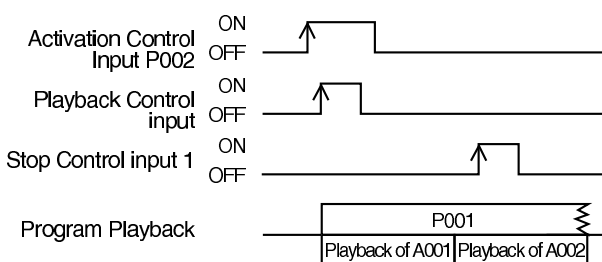

- Playback stops when the Stop Control input is shorted after the current sentence is played back.
- Programs cannot be played back while the Stop control input is shorted.

8.5.5. Busy output and playback delay time settings [5-3 BUSY OUTPUT SETTING]

[Busy output setting]

Perform the busy output ON/OFF setting at the time of program playback, sentence recording or erasure, system setting^(*1), and microphone announcement. Setting the playback busy output for ON sends out a contact signal from the busy output terminal corresponding to the output set for each program, whether in single-source or dual-source playback mode. The busy output ON/OFF for sentence recording/erasure, microphone announcement, and system setting can be set for each of busy outputs 1 and 2. Refer to p. 70 for the operation procedures.

Factory-preset values

- Playback busy output: ON for both busy outputs 1 and 2
- Busy output for sentence recording/erasure, system setting and microphone announcement: OFF for both busy outputs 1 and 2

*1 When the system busy is set for ON, the busy output is enabled while the following functions are being set or operating.

1-1 PROGRAM INPUT	7-1 CARD NAME INPUT
1-2 OUTPUT LEVEL	7-2 CARD REFORMATTING
1-4 PROGRAM INITIALIZATION	7-3 CARD OPTIMIZATION
1-5 PROGRAM TITLE	7-4 SOFTWARE WRITE PROTECT
2-3 SENTENCE TITLE	8-1 PROGRAM COPYING
2-4 INTERVAL ERASING (and its monitoring*2)	8-2 SENTENCE COPYING
3-1 SENTENCE MONITORING*2	8-3 CARD COPYING
3-2 PROGRAM MONITORING*2	9-1 AUTOMATIC LEVEL ADJUSTMENT

*2 Note that the busy output is not enabled even if the playback busy is set for ON.

Tip

Busy outputs to be set in the program input setting

Other than listed above, the busy outputs in program intervals of the single-program playback or in repeat intervals of the repeat playback can be set to ON/OFF for the busy output 1 or 2.

Refer to p. 33 "1-1 PROGRAM INPUT."

[Playback delay time setting]

Set the delay time from playback activation till program playback in the range of 0-99 seconds (in 1-second units).

Refer to p. 70 for the operation procedures.

Factory-preset value

Playback delay time: 0 second

8.6. Setting Functions (6. ENVIRONMENT SETTING)

8.6.1. Operation beep setting (6-1 OPERATION BEEP)

Whether to sound (ON) or not to sound (OFF) a beep when pressing the keys can be set.

Refer to p. 72 for the operation procedures.

Note: Factory-preset for ON.

8.6.2. RS-232C setting (6-2 RS-232C SETTING)

Set the RS-232C communication speed for 4,800 bps, 9,600 bps (factory-preset) or 19,200 bps.

Refer to p.72 for the operation procedures.

8.6.3. Password setting (6-3 PASSWORD)

Setting the password locks the keys to prevent malfunctions or tampering.

Refer to p. 72 for the operation procedures.

Note: Any password is not preset when the unit is supplied from the factory.

8.6.4. Initializing the digital announcer (6-4 DIGITAL ANNOUNCER INITIALIZATION)

All settings return to the initial values set by the factory.

The setting contents are initialized in the setting menus; "RECORDING SETTING," "4. OUTPUT/VOLUME SETTING," "5. OPERATION SETTING," "6. ENVIRONMENT SETTING," and "9. AUTO-LEVEL SETTING." Refer to p. 72 for the operation procedures.

8.6.5. Key lock setting (6-5 KEY LOCK)

This function allows the keys to be locked. You must set the password when using this function. Setting the key lock function for ON disables all the keys and dials except the power switch, preventing malfunctions and tampering.

Refer to p. 72 for the operation procedures.

Note: The key lock function is factory-preset for OFF.

8.6.6. Version indication (6-6 VERSION INDICATION)

Displays the version of the unit's program software. Select the corresponding item with the [SELECT] dial, and the version is displayed.

Refer to p. 72 for the operation procedures.

8.7. Setting Functions (7. EDITING THE CARDS)

You can assign a name to the card or re-format the card.

8.7.1. Entering or editing the card name (7-1 CARD NAME INPUT)

You can assign a name to the recorded card or modify the registered card name.

Refer to p. 74 for the operation procedures.

8.7.2. Reformatting the memory card (7-2 CARD REFORMATTING)

Cards can be re-formatted. Note that the whole of the recorded content is erased if the card is re-formatted.

Refer to p. 74 for the operation procedures.

8.7.3. Optimization of the cards (7-3 CARD OPTIMIZATION)

Erasing the sentences in the card may shorten the card's remaining recording time. This, however, can be avoided by optimizing the card. Be sure to optimize the card after erasing the sentences.

Refer to p. 76 for the operation procedures.

8.7.4. Software-operated write protection (7-4 SOFTWARE WRITE PROTECT)

Recorded or set contents of the card can be protected. Protecting the card makes it impossible to register, erase or edit sentences, and to change programs. It is highly recommended that the finished card be protected to avoid the accidental erasure of the card's contents. Programs can be played back or verified, and sentences verified even if the card is protected.

Note: The software-operated write protection function is factory-preset for OFF for both cards A and B.

When the SRAM card is used, it is protected as follows depending on the card's write protect (WP) switch setting and the on-off status of the software-operated write protection.

WP switch: WP position, software write protection: ON → Protection ON

WP switch: WP position, software write protection: OFF → Protection ON

WP switch: Opposite position of WP, software write protection: ON → Protection ON

WP switch: Opposite position of WP, software write protection: OFF → Protection OFF

Note that the software-operated write protection cannot be set if the WP switch is already set to WP position. To disable the protection of the card with the WP switch in WP position after setting the software-operated write protection for ON, set the WP switch to WP position first, then set the software-operated protection for OFF.

Refer to p. 76 for the operation procedures.

8.8. Setting Functions (8. COPYING THE PROGRAM, SENTENCE AND CARD)

You can copy a created program or recorded sentence to the new program number or new sentence number over both cards. In addition, the whole content of one card can be copied to another card.

8.8.1. Copying a program (8-1 PROGRAM COPYING)

You can copy a created program to a different program number.
Refer to p. 77 for the operation procedures.

Note: The program to be copied overwrites the program to copy to.

8.8.2. Copying a sentence (8-2 SENTENCE COPYING)

You can copy a recorded sentence to a new sentence number.
Refer to p. 78 for the operation procedures.

Note: Emergency sentences cannot be copied.

8.8.3. Copying the memory card (8-3 CARD COPYING)

You can copy the whole content of one card to another card. Insert the card to be copied into card slot A, and the card to copy to into slot B.
Refer to p. 78 for the operation procedures.

Note: Both cards must be identical in type and capacity.

[Copy error message]

1. The following error message is displayed when the destination card (card B) is insufficient.

```
CARD  CAPA LOW.  
CHANGE CARD.
```

2. Prepare a new memory card with larger capacity.

8.8.4. What if an error message is displayed while copying the sentence?

1. The following message is displayed when the sentence is copied and the memory capacity (remaining time) to be copied is insufficient.

```
CARD  CAPA LOW.  
CHANGE CARD.
```

2. In such cases, first increase the capacity as shown below, and then copy the sentence again.
 - (1) Optimizing the memory card to copy to could increase its capacity. (Refer to p. 76 "7-3 CARD OPTIMIZATION.")
 - (2) If copying is still impossible even when the card is optimized, prepare a new memory card with larger capacity. (When only one card is in use, install one more card.)

Tips

- (1) Recording grade (Long, Normal, High or Extremely High) set for the source card is applied to the sentence copying regardless of the unit's recording grade setting.
- (2) The recording time and recording grade can be checked from the following indications: (Refer to p. 62 "2-1 SENTENCE VERIFICATION.")

```
Sentence No.  Recording grade: L (Long)  
[A001] VERIF32N  N (Normal)  
MESSAGE1 0:00:10 H1 (High)  
H2 (Extremely High)  
Sentence title  Recording time
```

- (3) The remaining recording time which permits sentence copying can be checked from the following indications:

However, to make this check, the unit must be set for the same recording grade as the source sentence to be copied in the recording setting. If the setting differs, the remaining time cannot be accurately shown. (Refer to p. 22 "Recording setting procedure.")

```
[A001] ■  
MANU REC 0:06:40  
Remaining recording time
```

8.9. Setting Functions (9. AUTO-LEVEL SETTING)

8.9.1. Automatic level adjustment (9-1 AUTOMATIC LEVEL ADJUSTMENT)

Setting the automatic level adjustment function for ON allows the sentences recorded at different recording signal levels to be played back at the uniform level when playing back a program. Depending on the programs, the playback sound may not be smooth to the ears. In such a case, set the automatic level adjustment function for OFF.

Refer to p. 80 for the operation procedures.

Note: Factory-preset for OFF.

9. SETTING OPERATION

9.1. An Example of Operation Procedures

How to make settings is explained here referring to an example of the "1-1 PROGRAM INPUT" (See p. 33 and 54.).

In this example, the sentence Nos. A001 and A005 are assigned to the program No. P001. Moreover the Playback method and Output channel are set as shown below.

Program No.	Playback method	Step No.	Editing	Sentence No.	Output
P001	Continuous program playback	001	Step input	A001	Output 1
		002		A005	

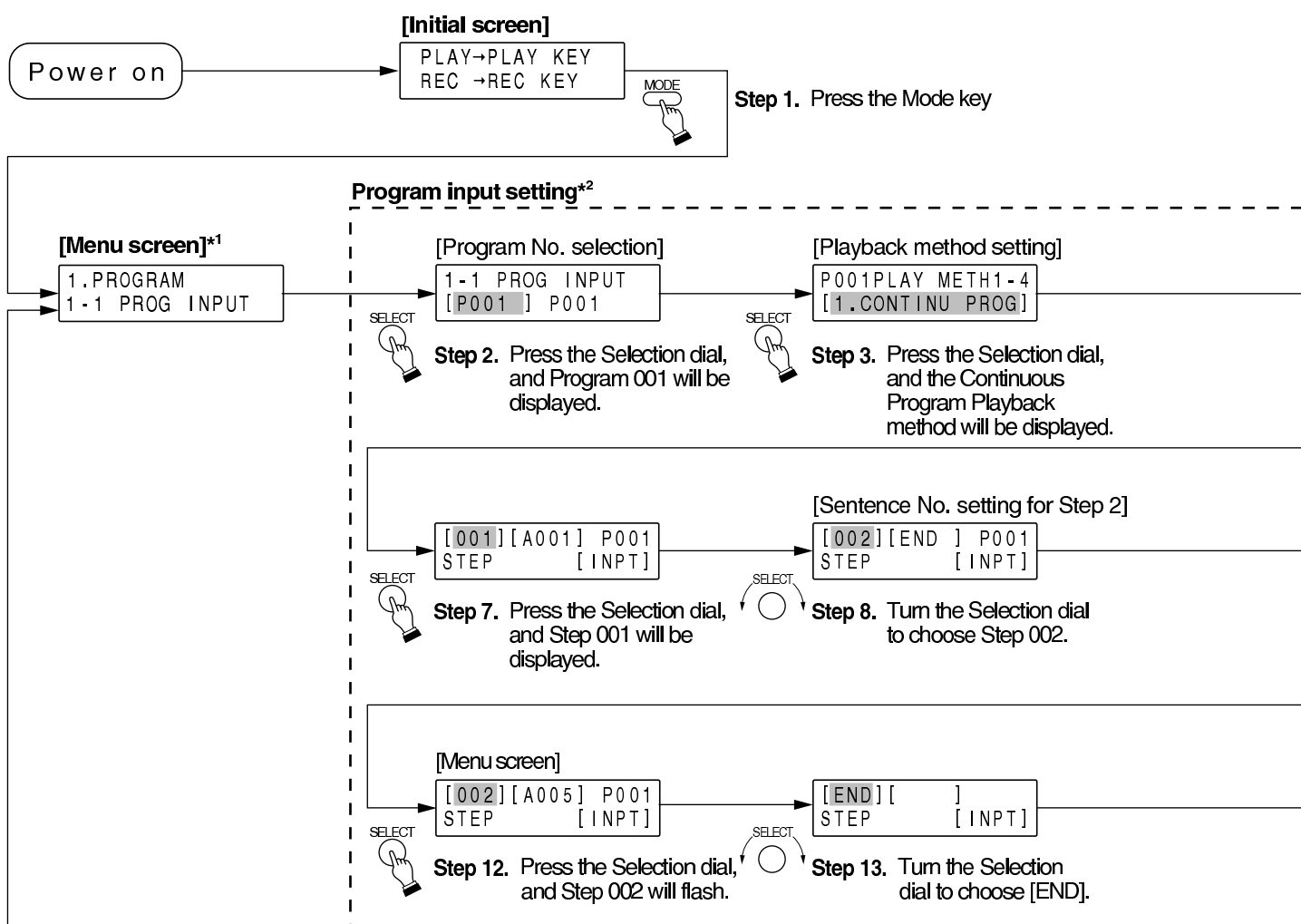

*1 Pressing the [STOP] key while the menu screen is displayed returns the display to the initial screen.

*2 Pressing the [STOP] key while the function setting screen is displayed returns the display to the previous menu screen.

Note: When the function setting is completed, the screen returns to the menu screen. To terminate all setting operations, further press the [STOP] key to return to the initial screen.

[Program Initial Setting Value]

Playback Method	Program Title	Step No.	Sentence No.	Output
Continuous Program Playback	P001-P256 (Same as program numbers)	001 only	A001 for P001 ⋮ A128 for P128 B001 for P129 ⋮ B128 for P256 (1 sentence only for each program)	Output 1 and Output 2

If the program input is not executed, the playback operates in accordance with the initial settings preset at the factory.

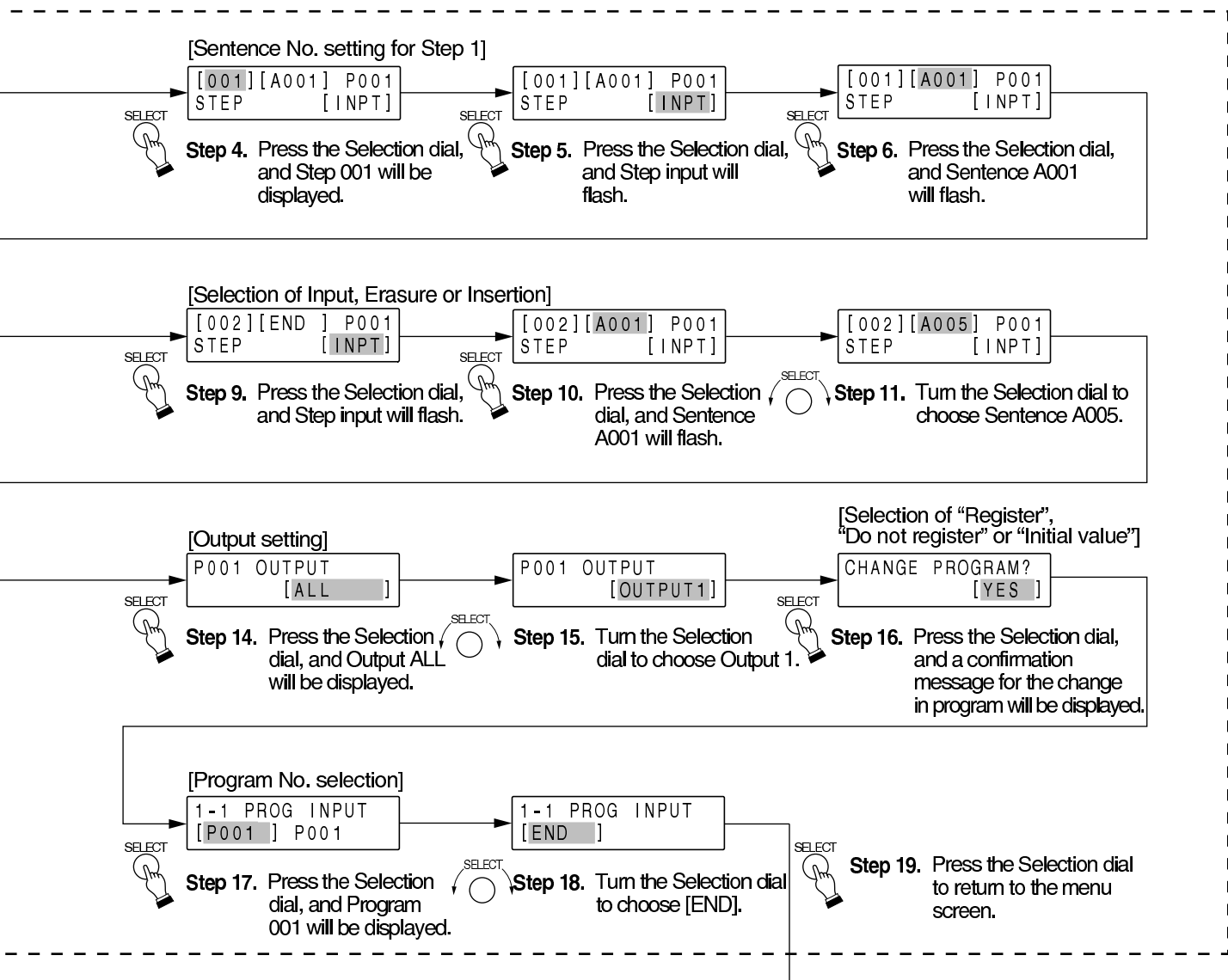

9.2. Setting Operation (1. PROGRAM)

9.2.1. Operation procedures (1-1 PROGRAM INPUT)

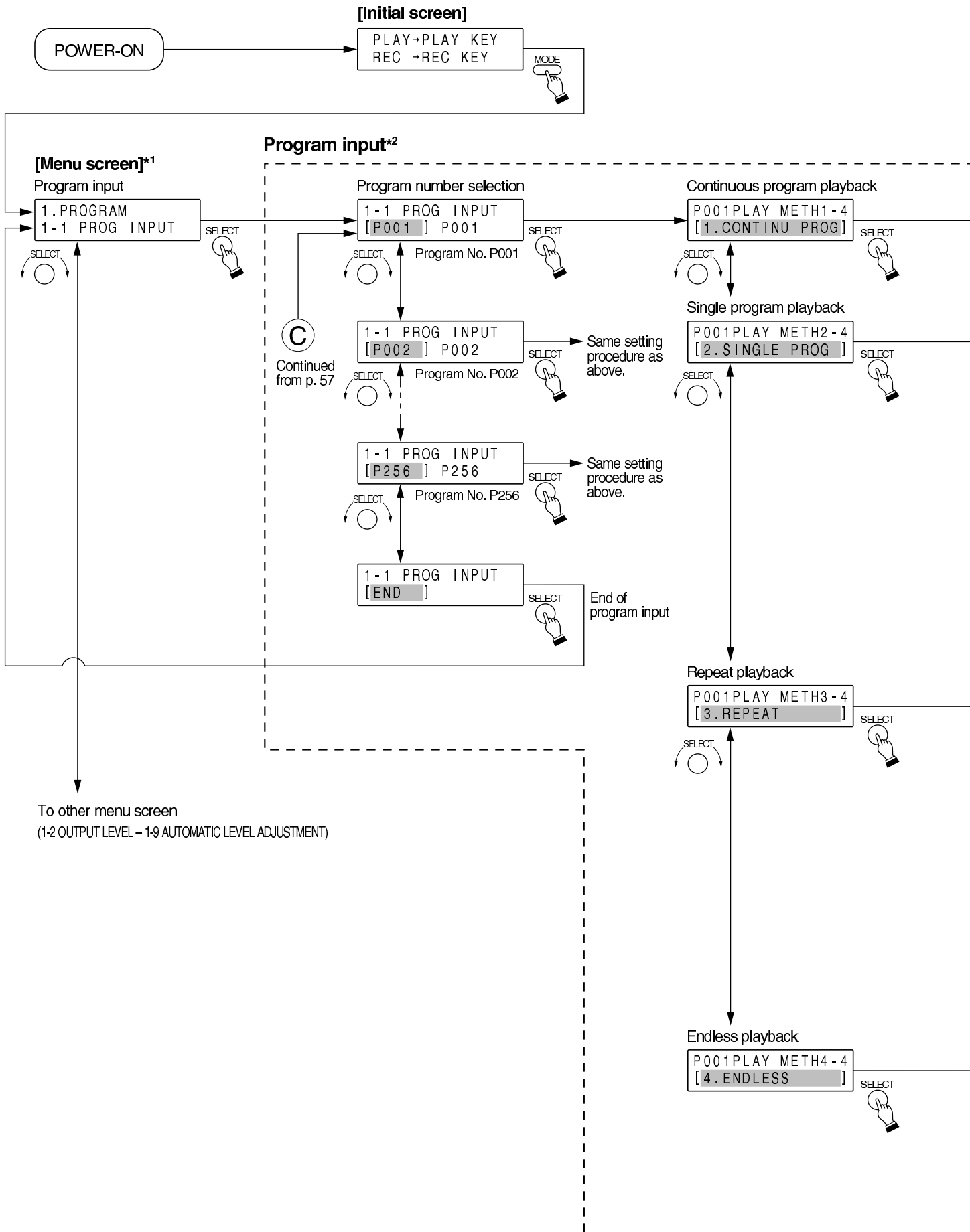

*1 Pressing the [STOP] key while the menu screen is displayed returns the display to the initial screen.

*2 Pressing the [STOP] key while the function setting screen is displayed returns the display to the previous menu screen.

Note: When the function setting is completed, the screen returns to the menu screen. To terminate all setting operations, further press the [STOP] key to return to the initial screen.

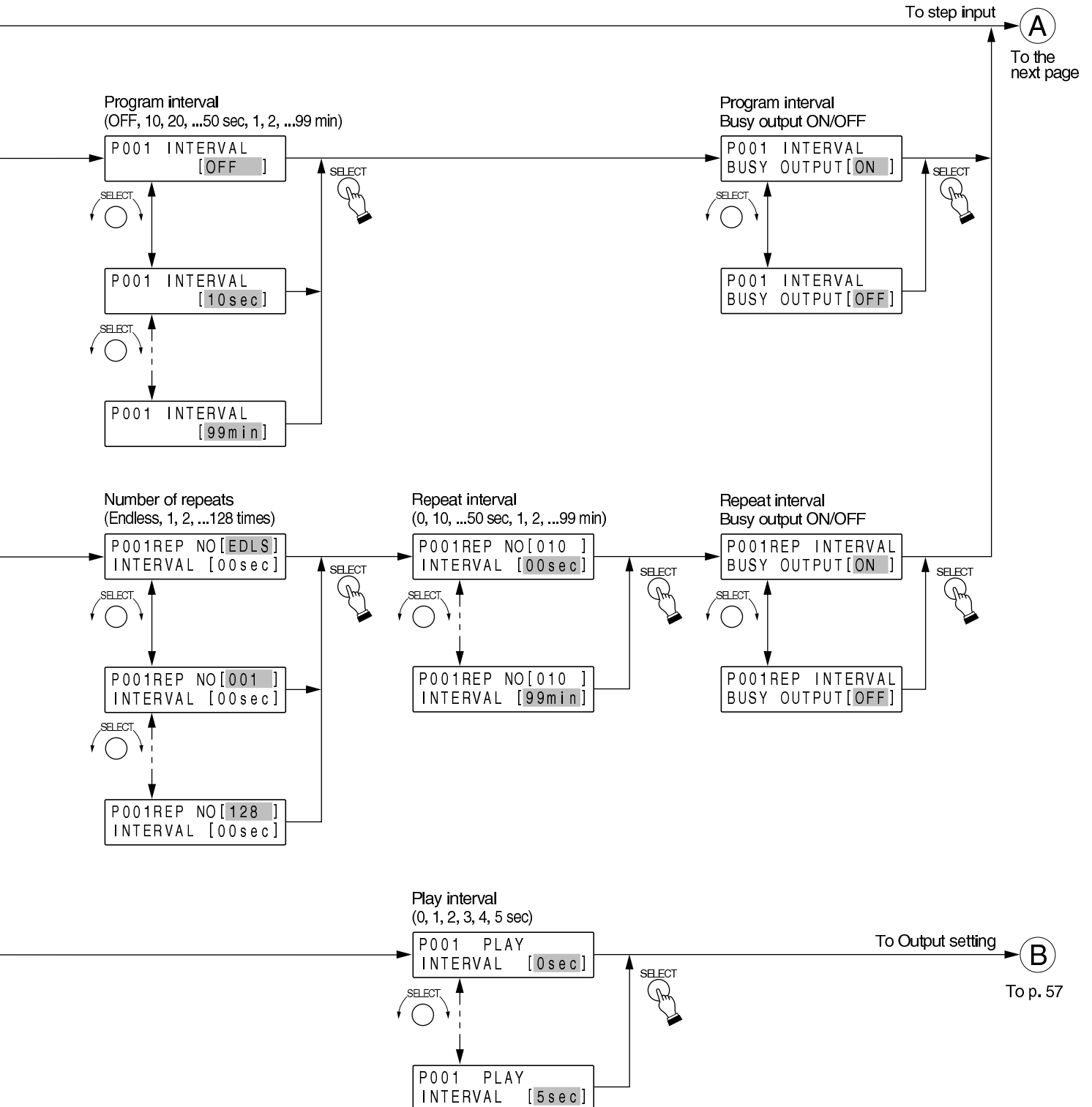

Program input

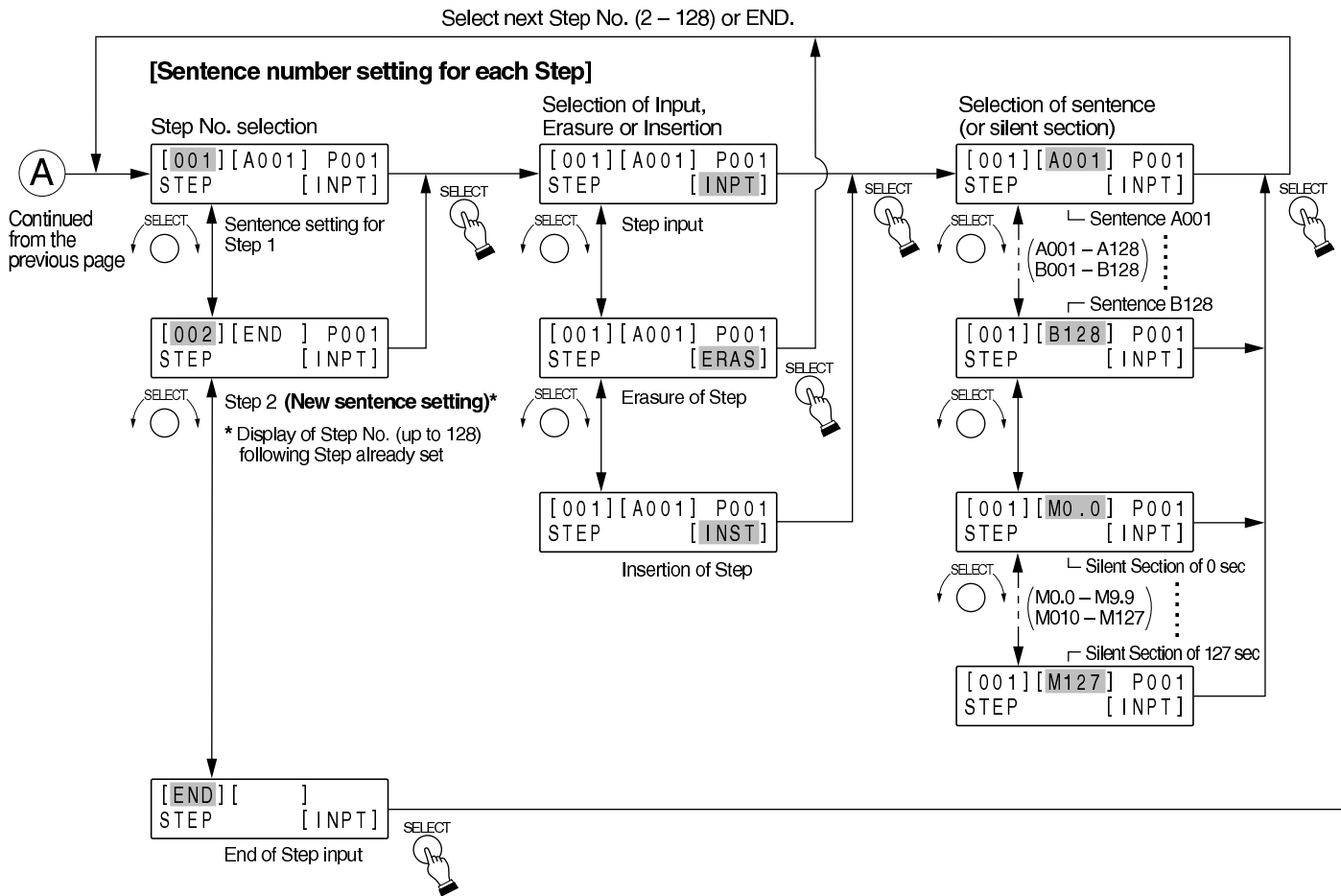

[Selection item and setting contents] (Program input)

Program No.	Setting Contents				
	Playback method	Program interval (Interval Timer)	Number of plays	Play interval	Busy output
P001 – P256	<u>Continuous Program Playback</u>	—	—	—	—
	Single Program Playback	OFF (no relation) 10, 20, ... 50 sec 1, 2, ... 99 min	—	—	ON (At program interval) OFF
	Repeat Playback	—	1, 2, ... 128 repeats, Endless	0, 10, ... 50 sec 1, 2, ... 99 min	ON (At repeat interval) OFF
	Endless Playback	—	—	0, 1, 2, 3, 4, 5 sec	—

Notes

Initial value (set by the factory)

- Underlined part refers to the initial value.
- Sentence No. A001 – A128 are assigned to Program No. P001 – P128, and Sentence No. B001 – B128 to Program No. P129 – P256. (Only one sentence is set for each program.)

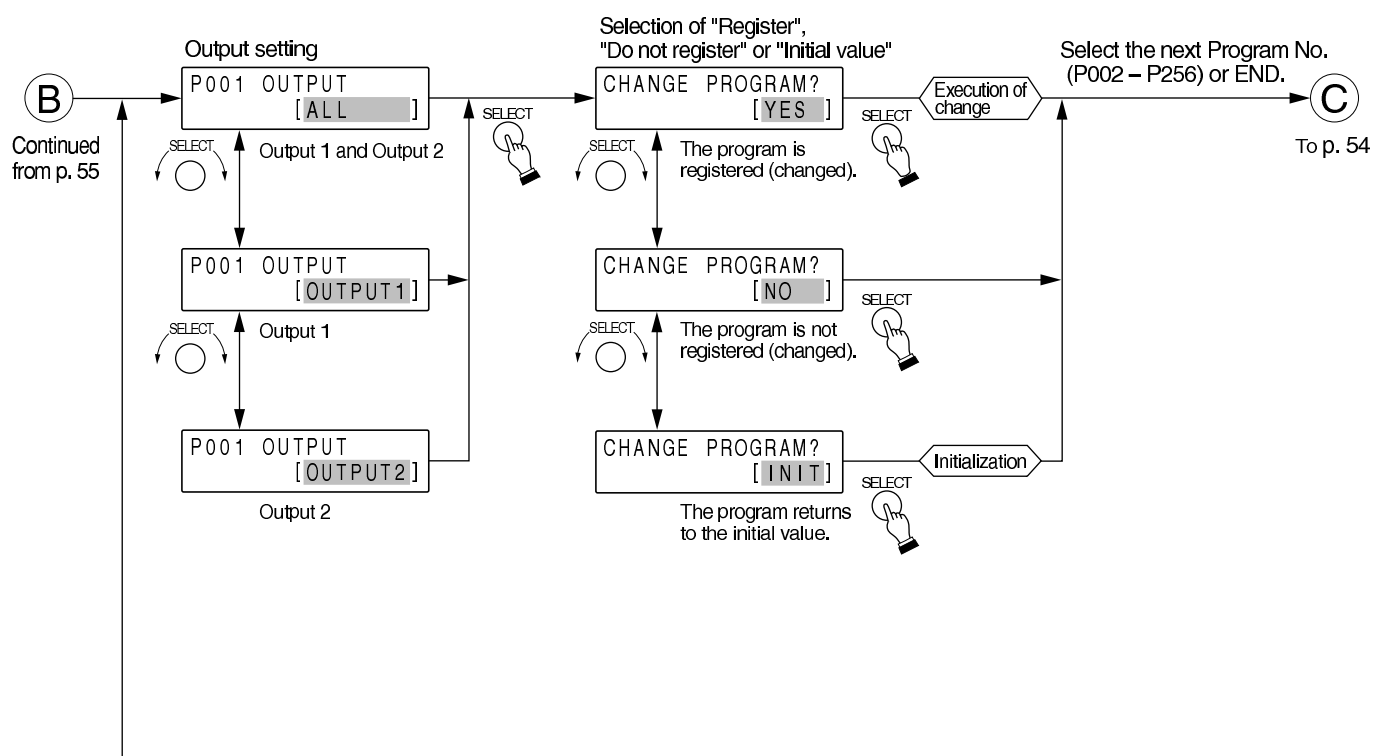

Step No.	Setting Contents		
	Editing	Sentence No. (or Silent Section)	Output
001 - 256	Step input Step input deletion Step input insertion	Sentence No.: A001 - A128 B001 - B128 Silent section's silence interval: M0.0 - M9.9 (0 - 9.9 sec, 0.1 sec units) M010 - M127 (10 - 127 sec, 1 sec units)	Output 1 and Output 2 Output 1 Output 2

9.2.2. Operation procedures (1-2 OUTPUT LEVEL and 1-3 PROGRAM VERIFICATION)

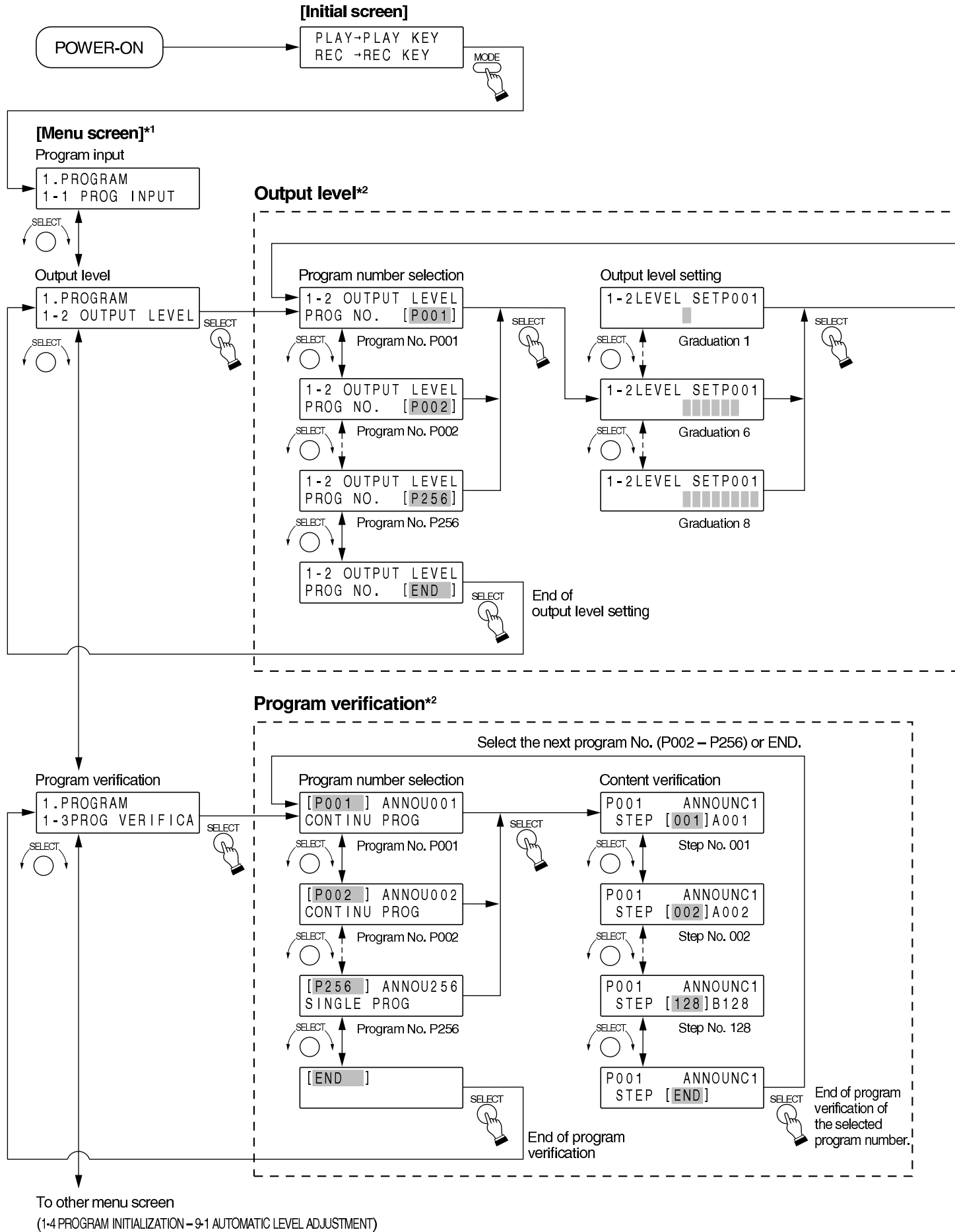

*1 Pressing the [STOP] key while the menu screen is displayed returns the display to the initial screen.

*2 Pressing the [STOP] key while the function setting screen is displayed returns the display to the previous menu screen.

Note: When the function setting is completed, the screen returns to the menu screen. To terminate all setting operations, further press the [STOP] key to return to the initial screen.

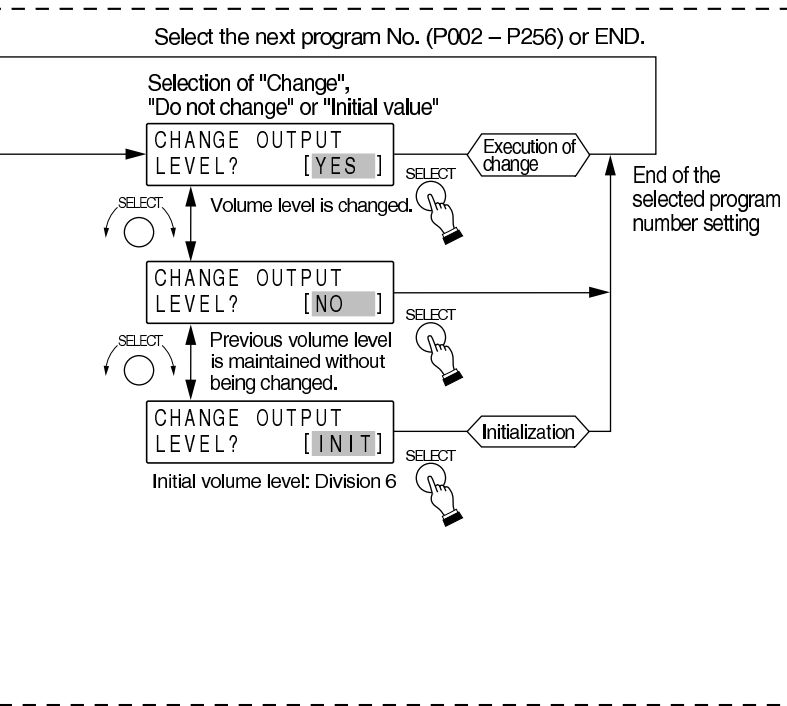

[Selection item and setting contents] (Output level)

Program No.	Setting Contents
	Output Level
P001 – P256	Graduation 1
	Graduation 2
	⋮
	Graduation 6
	Graduation 7
	Graduation 8

Underlined parts refer to the initial value (set by the factory).

[Selection item and contents to verify] (Program verification)

Program No.	Contents to Verify		Step No.	Contents to Verify
	Program Title	Playback method		Sentence No. (or Silent Section)
P001 – P256	<u>P001 – P256</u> Up to 8 alphanumeric characters	<u>Continuous Program Playback</u>	001 – 256	Sentence No.: <u>A001 – A128</u> B001 – B128 Silent section's silence interval: M0.0 – M9.9 (0 – 9.9 sec, 0.1 sec units) M010 – M127 (10 – 127 sec, 1 sec units)
		Single Program Playback		
		Repeat Playback		
		Endless Playback		
			—	—

Underlined parts refer to the initial value (set by the factory).

9.2.3. Operation procedures (1-4 PROGRAM INITIALIZATION and 1-5 PROGRAM TITLE)

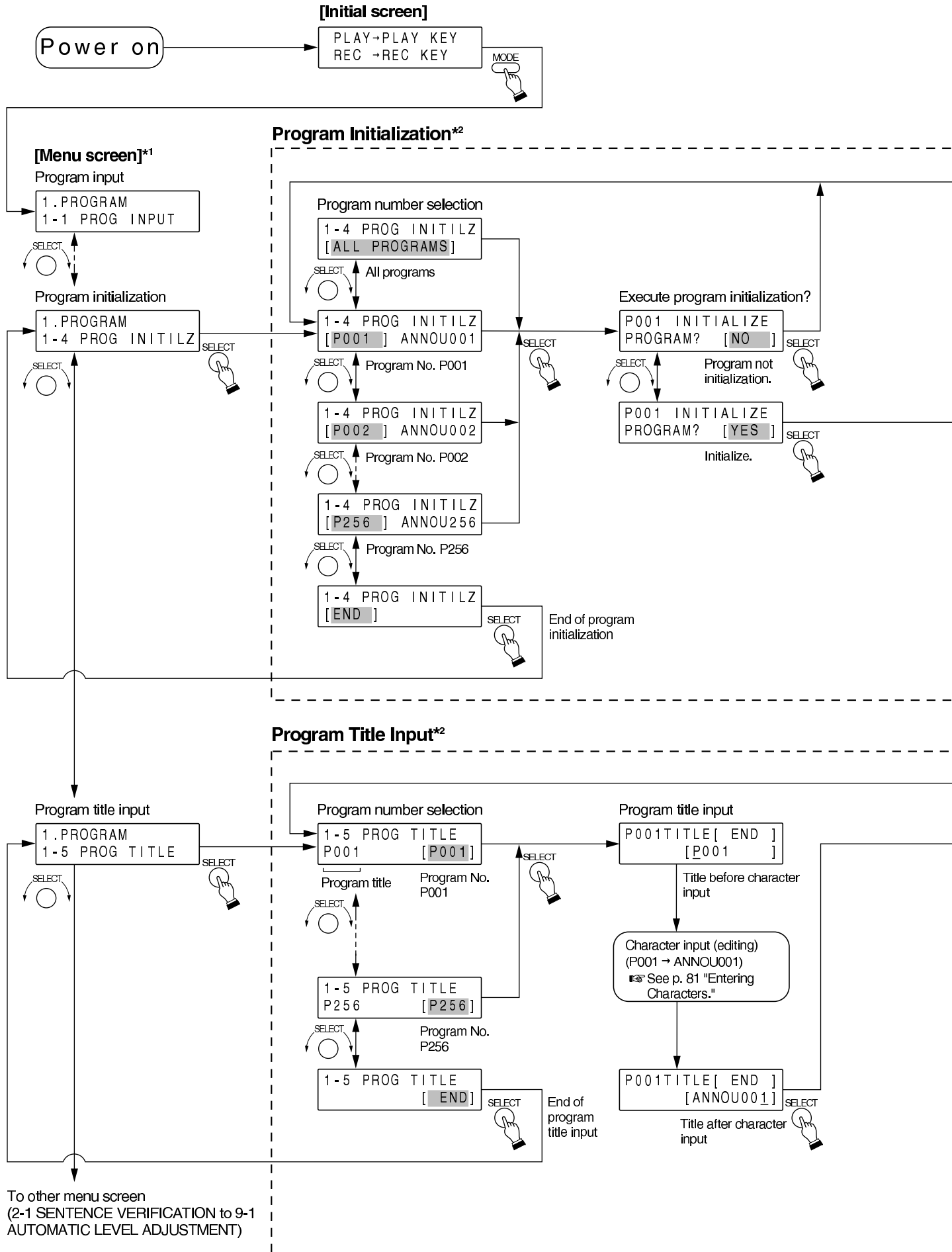

*1 Pressing the [STOP] key while the menu screen is displayed returns the display to the initial screen.

*2 Pressing the [STOP] key while the function setting screen is displayed returns the display to the previous menu screen.

Note: When the function setting is completed, the screen returns to the menu screen. To terminate all setting operations, further press the [STOP] key to return to the initial screen.

Select the next program number (P002–P256 or All programs) or END.

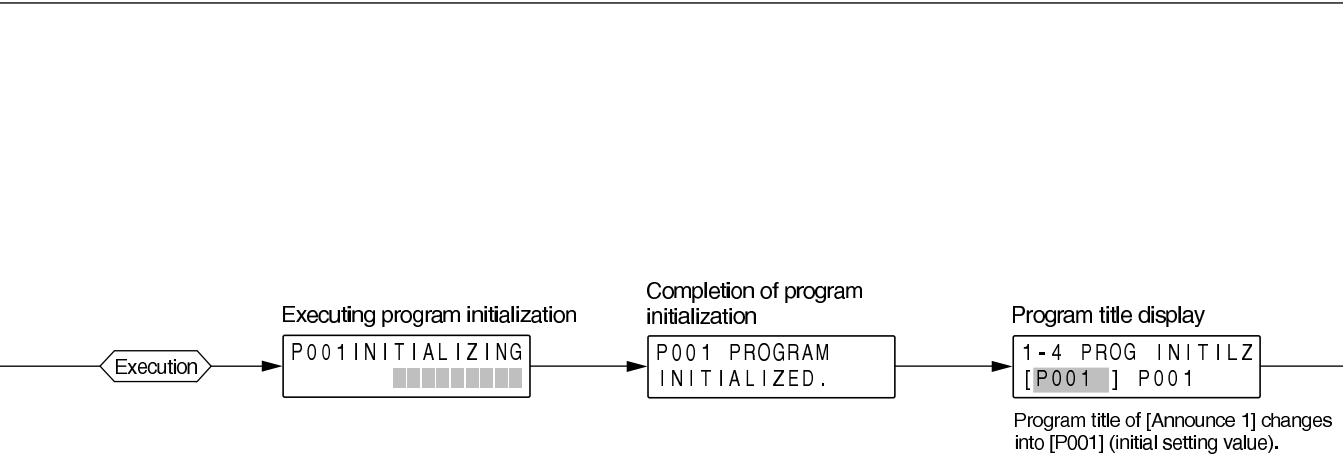

[Program Initial Setting Value]

Playback Method	Program Title	Step No.	Sentence No.	Output
Continuous Program Playback	P001-P256 (Same as program numbers)	001 only	A001 for P001 : A128 for P128 B001 for P129 : B128 for P256 (1 sentence only for each program)	Output 1 and Output 2

Select the next program number (P002–P256) or END.

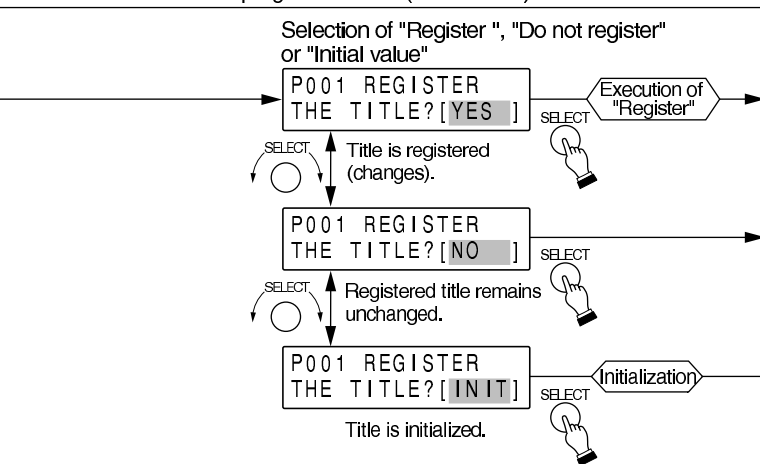

[Selection items and setting contents]

Program No.	Program Title
P001-P256	P001-P256 (same as program numbers)

9.3. Setting Operation (2. EDITING THE SENTENCES)

9.3.1. Operation procedures (2-1 SENTENCE VERIFICATION and 2-2 SENTENCE ERASURE)

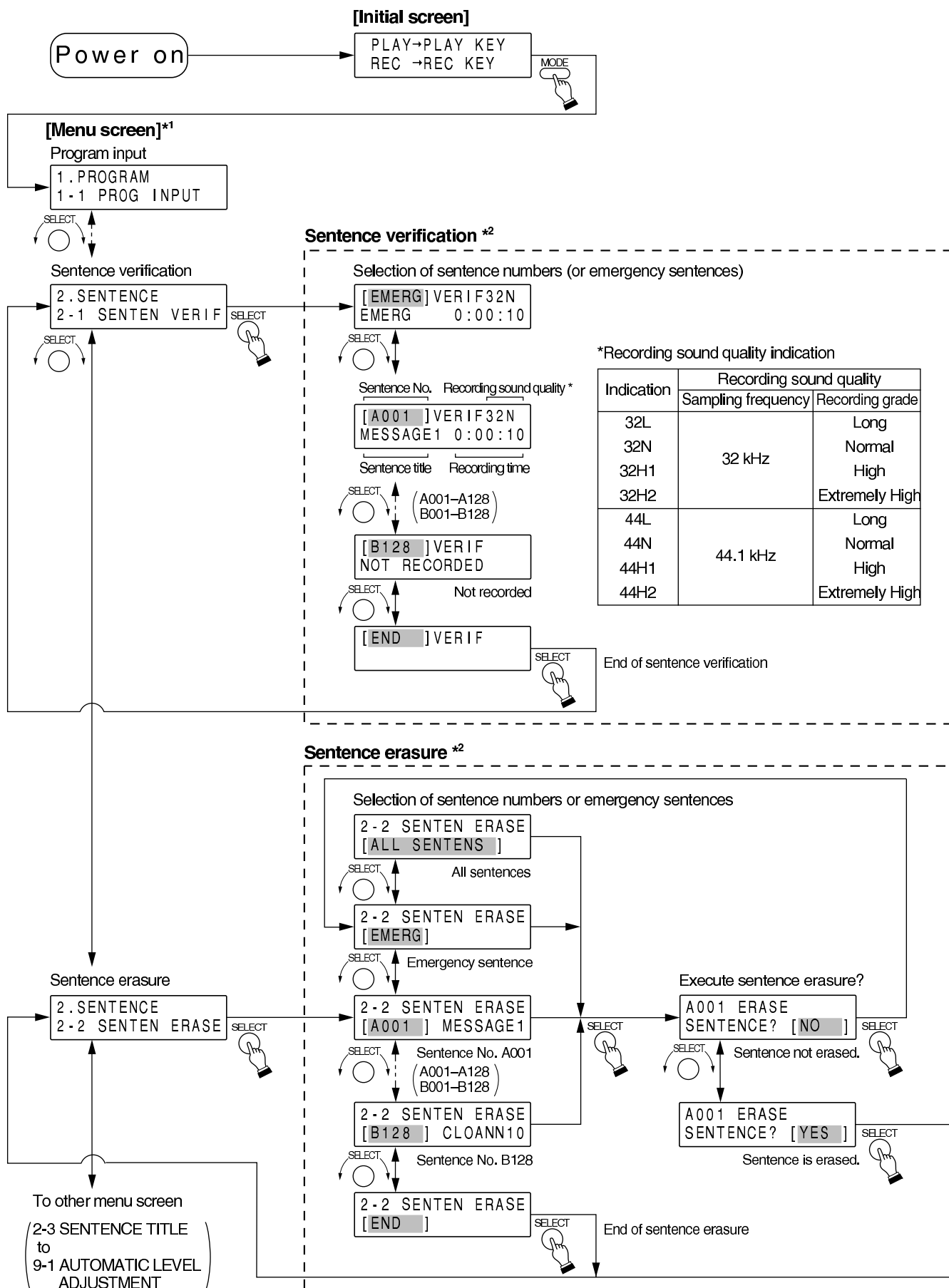

*1 Pressing the [STOP] key while the menu screen is displayed returns the display to the initial screen.

*2 Pressing the [STOP] key while the function setting screen is displayed returns the display to the previous menu screen.

Note: When the function setting is completed, the screen returns to the menu screen. To terminate all setting operations, further press the [STOP] key to return to the initial screen.

[Selection items and contents to verify] (Sentence verification)

Sentence No.	Contents to Verify		
	Sentence Title	Recording Sound Quality	Recording Interval
A001- A128 B001 - B128	A001-A128 B001-B128 Title character (Up to 8 alphanumeric characters)	32L	X : YY : ZZ (X: Hour Y: Minute Z: Second)
		32N	
		32H1	
		32H2	
		44L	
		44N	
		44H1	
		44H2	

- (1) The title of the emergency sentence is displayed as "Emergency", while the sentence not recorded is displayed as "not recorded".
- (2) Underline parts refer to the initial value (set by the factory).

[Selection item] (Sentence erasure)

Sentence No.
All sentences
Emergency sentence
A001-A128
B001-B128

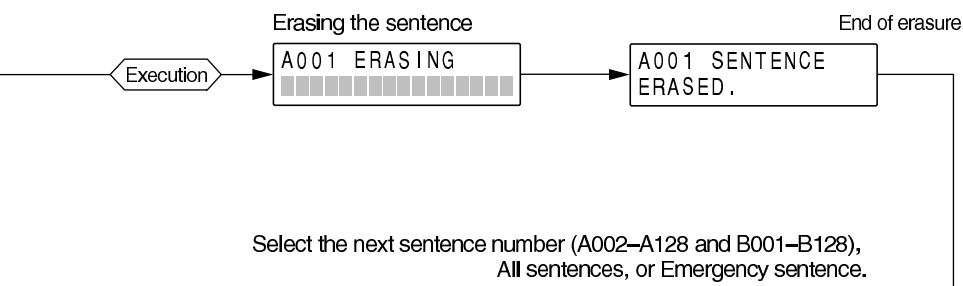

9.3.2. Operation procedures (2-3 SENTENCE TITLE and 2-4 INTERVAL ERASING)

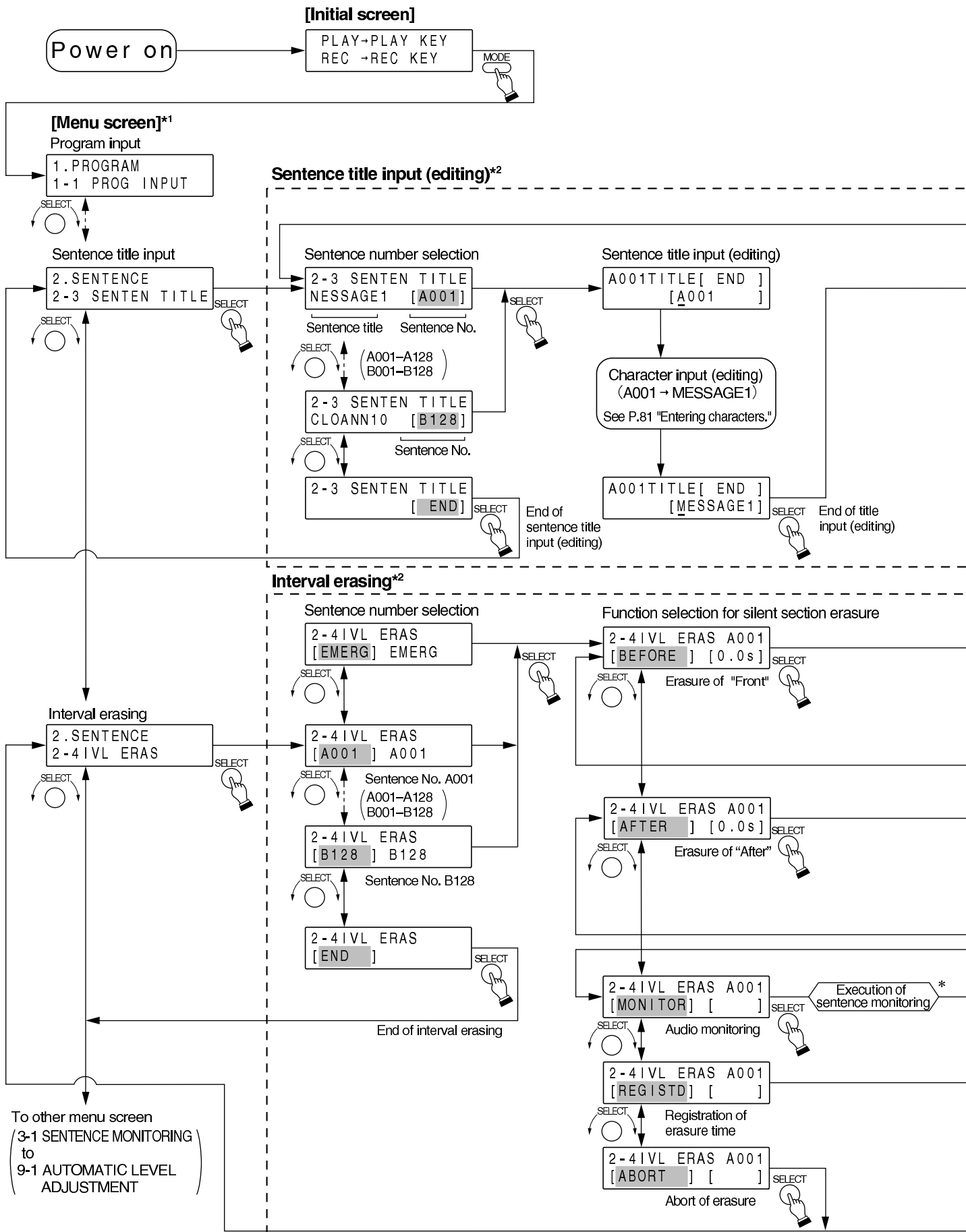

*1 Pressing the [STOP] key while the menu screen is displayed returns the display to the initial screen.

*2 Pressing the [STOP] key while the function setting screen is displayed returns the display to the previous menu screen.

Note: When the function setting is completed, the screen returns to the menu screen. To terminate all setting operations, further press the [STOP] key to return to the initial screen.

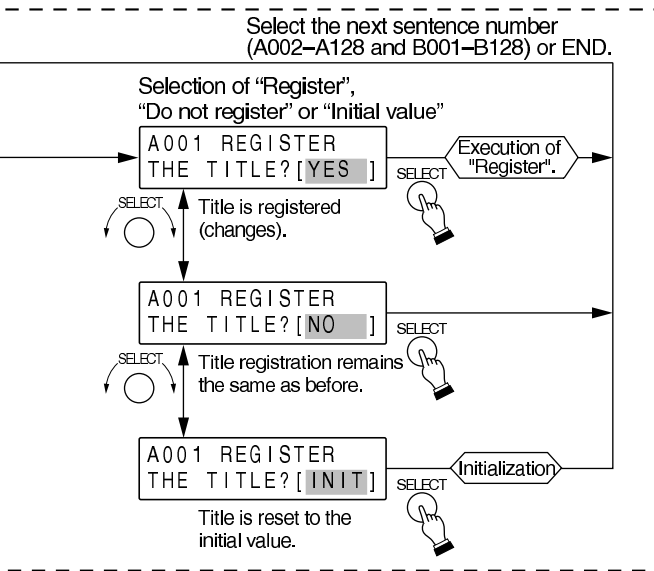

[Selection item] (Sentence title input)

Sentence No.	Sentence Title
A001-A128	<u>A001-A128</u>
B001-B128	<u>B001-B128</u>
	Character entry, insertion and erasure (up to 8 alphanumeric characters)

Note: Underlined parts refer to the initial value (set by the factory).

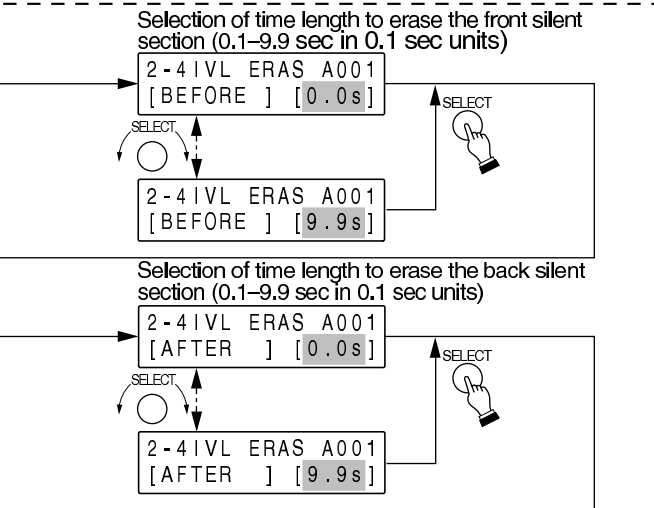

[Silent section of the sentence]

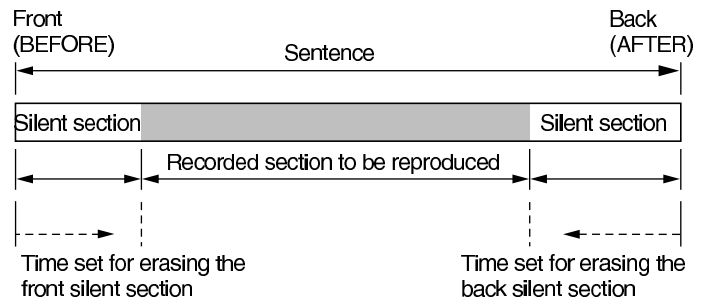

***Silent section erasure monitoring**

- When the sentence before it is modified is shorter than 10 seconds in length, the entire sentence is played back.
- When the sentence before it is modified is longer than 10 seconds in length, Front (BEFORE) is played back for 5 seconds, which is followed by another 5-second playback of Back (AFTER) following a 0.5 second pause.

When modifying the erasure time, go to [BEFORE] or [AFTER] screen. When the result of monitoring is OK, go to [REGISTER] screen.

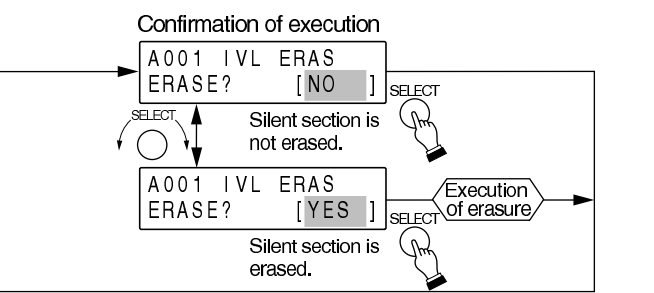

[Selection items and setting contents] (Interval erasing)

Sentence No.	Setting Contents	
	Front silent section erasure time	Back silent section erasure time
Emergency A001-A128 B001-B128	0- 9.9 sec (in 0.1 sec units)	0- 9.9 sec (in 0.1 sec units)

9.4. Setting Operation (3. MONITORING THE SENTENCES AND PROGRAMS)

9.4.1. Operation procedures (3-1 SENTENCE MONITORING and 3-2 PROGRAM MONITORING)

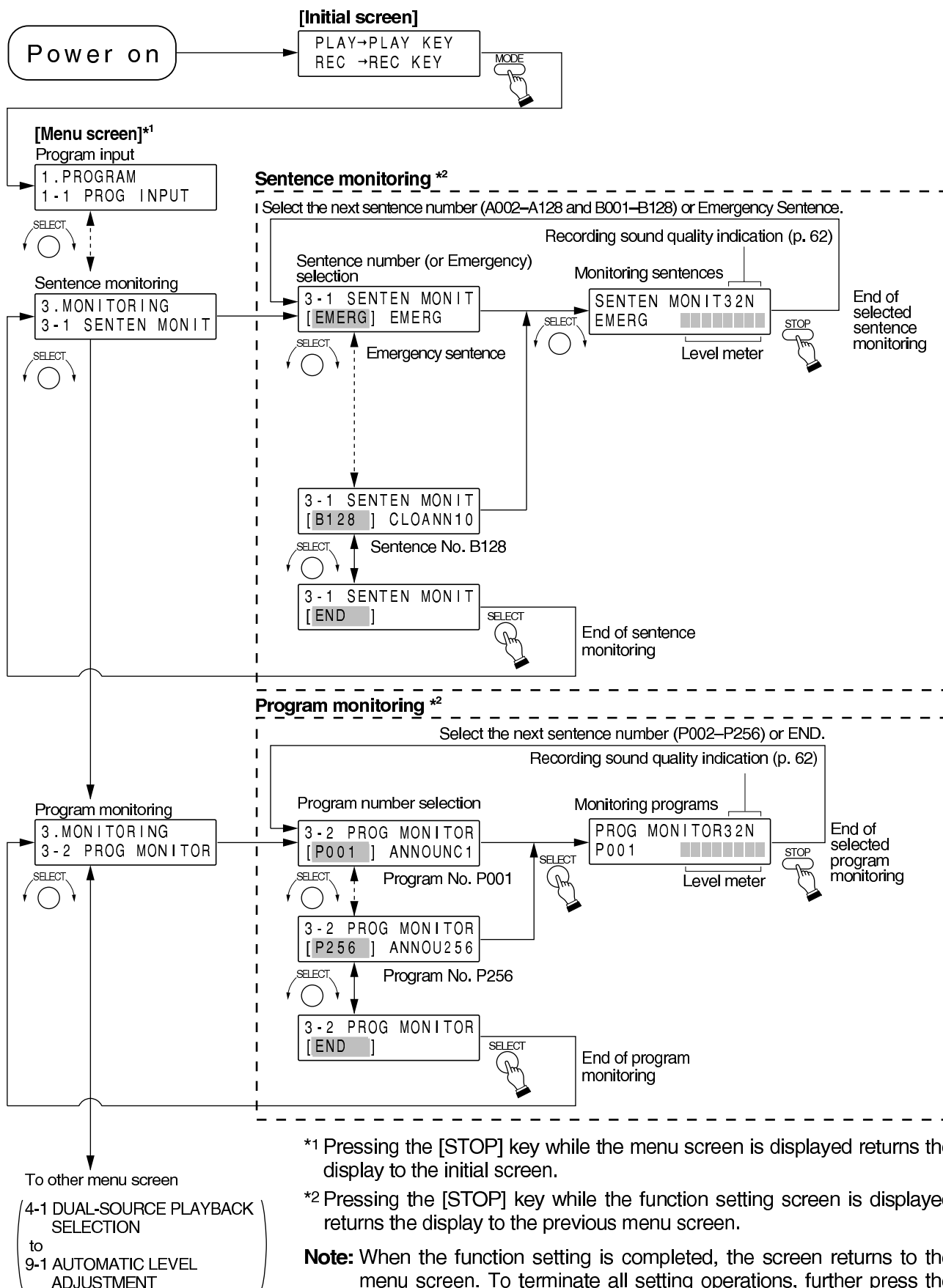

9.5. Setting Operation (4. OUTPUT/VOLUME SETTING)

9.5.1. Operation procedures (4-1 DUAL-SOURCE PLAYBACK SELECTION and 4-2 MASTER VOLUME)

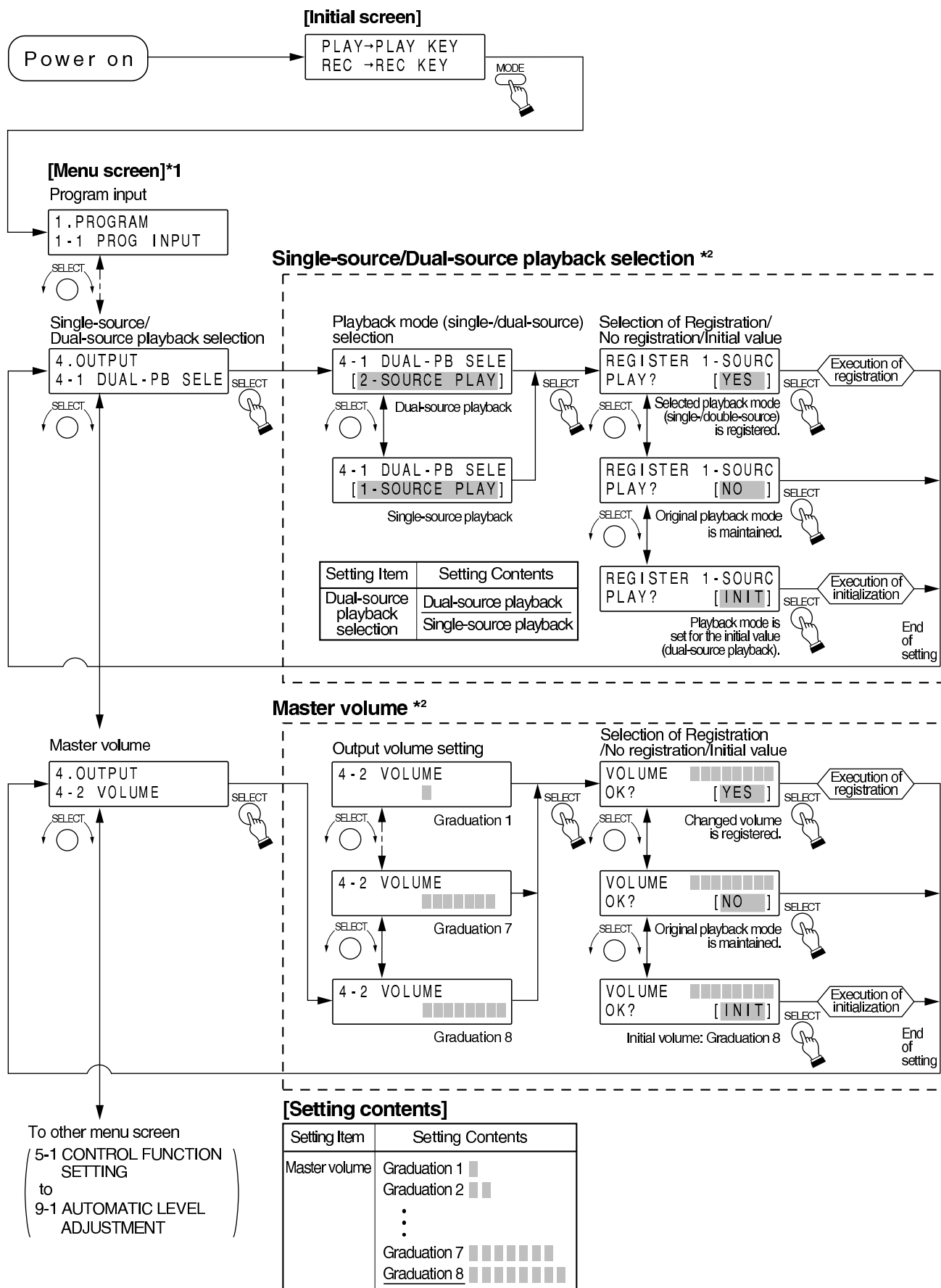

Note: Underlined part refers to the initial value (set by the factory).

9.6. Setting Operation (5. OPERATION SETTING)

9.6.1. Operation procedures

(5-1 CONTROL FUNCTION SETTING and 5-2 ACTIVATION MODE SELECTION)

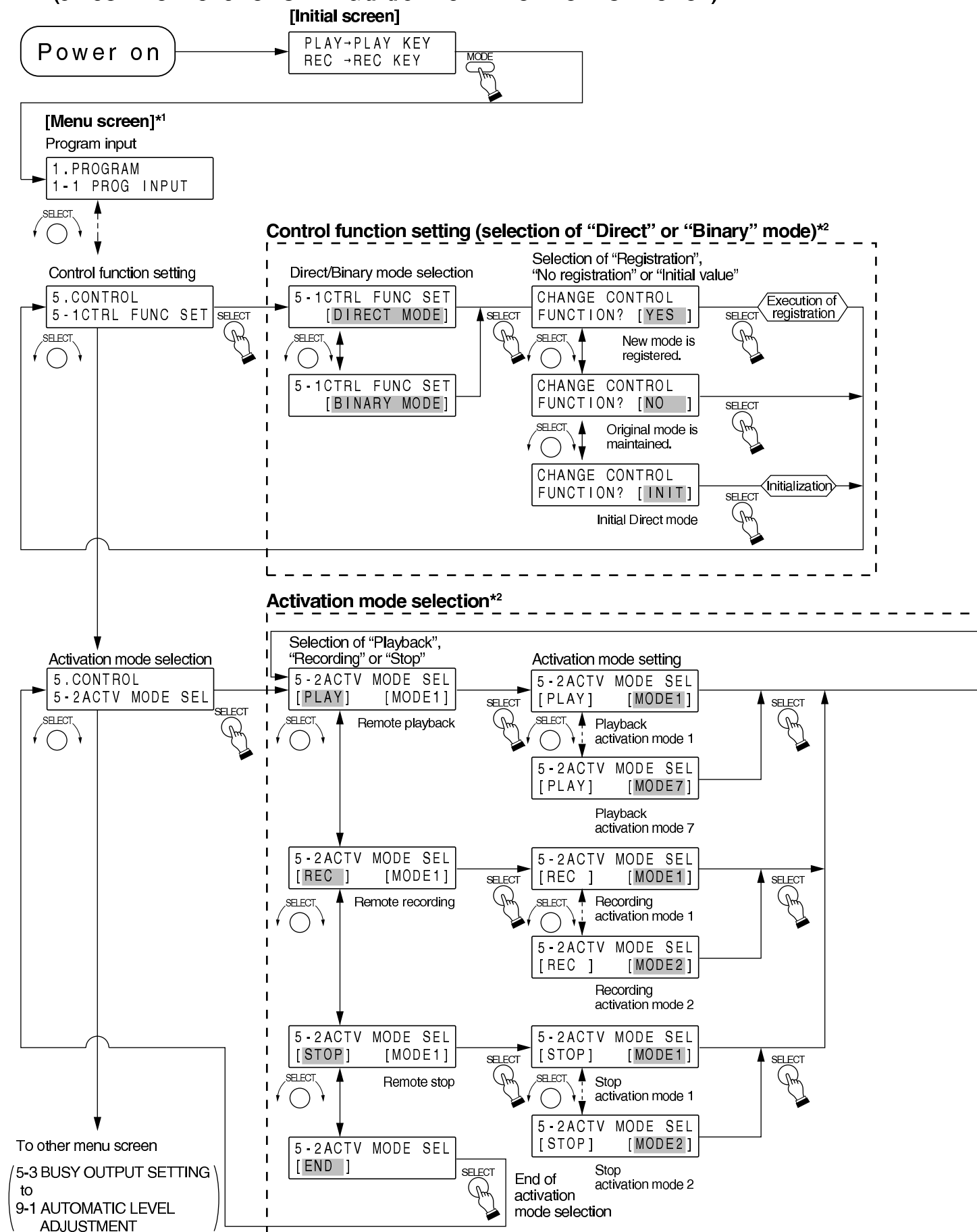

*1 Pressing the [STOP] key while the menu screen is displayed returns the display to the initial screen.

*2 Pressing the [STOP] key while the function setting screen is displayed returns the display to the previous menu screen.

Note: When the function setting is completed, the screen returns to the menu screen. To terminate all setting operations, further press the [STOP] key to return to the initial screen.

[Selection item and setting contents] (Activation mode selection)

Playback/recording/ stop	Setting contents		Description of activation mode
	Direct mode	Binary mode	
Remote playback	Activation mode 1	Activation mode 1	Mode 1: One-shot pulse activation, last-in rejected priority
	Activation mode 2	Activation mode 2	Mode 2: One-shot pulse activation, last-in-first-out priority
	Activation mode 3	Activation mode 3	Mode 3: One-shot pulse activation, smaller program No. priority
	Activation mode 4	Activation mode 4	Mode 4: One-shot pulse activation, sequential storage/playback
	Activation mode 5	Activation mode 5	Mode 5: Level-operated activation, first-in-first-out priority (This priority applies to the direct mode only.)
	Activation mode 6		Mode 6: Level-operated activation, last-in-first-out priority
	Activation mode 7		Mode 7: Level-operated activation, smaller program No. priority
Remote recording	Activation mode 1		Mode 1: One-shot pulse activation
	Activation mode 2		Mode 2: Level-operated activation
Remote stop	Activation mode 1		Mode 1: Stop during playback
	Activation mode 2		Mode 2: Stop after sentence playback completion

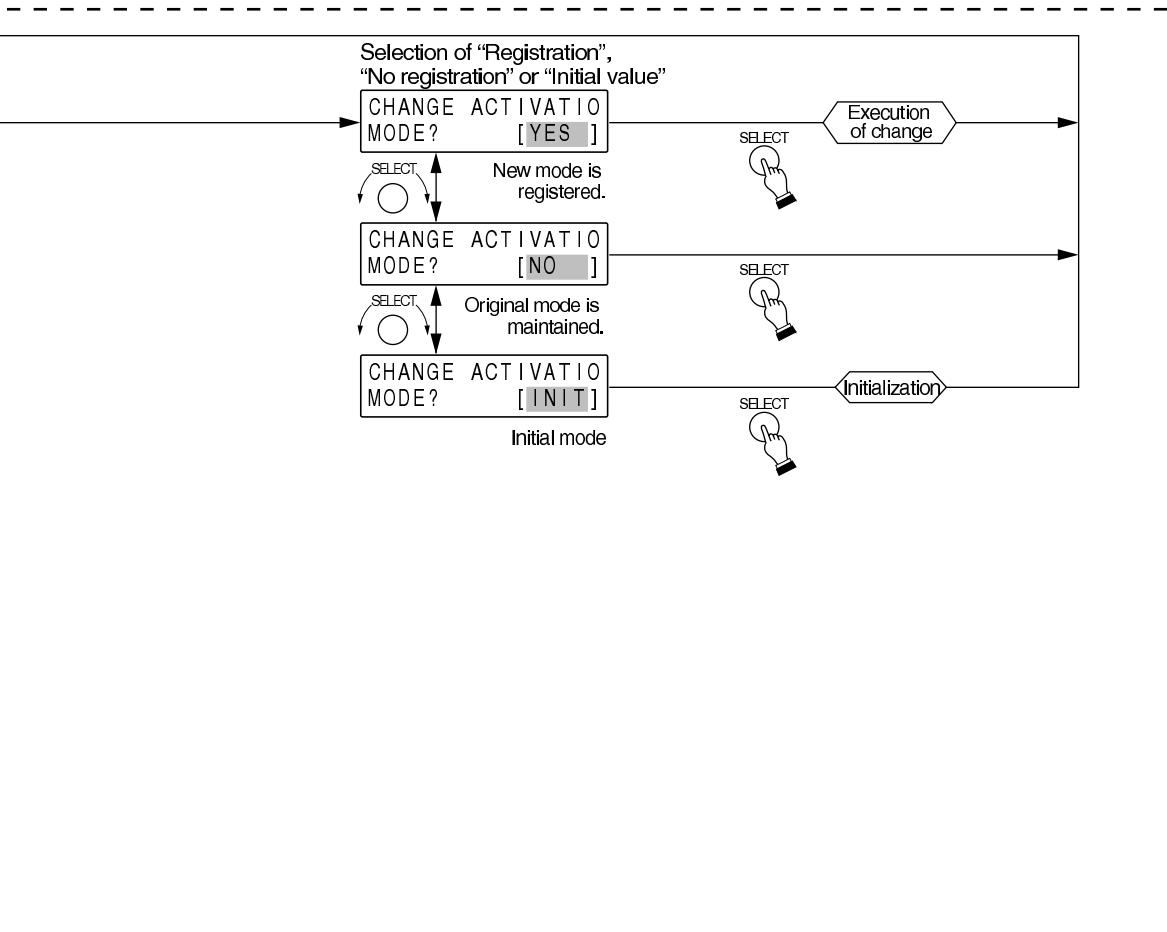

9.6.2. Operation procedures (5-3 BUSY OUTPUT SETTING)

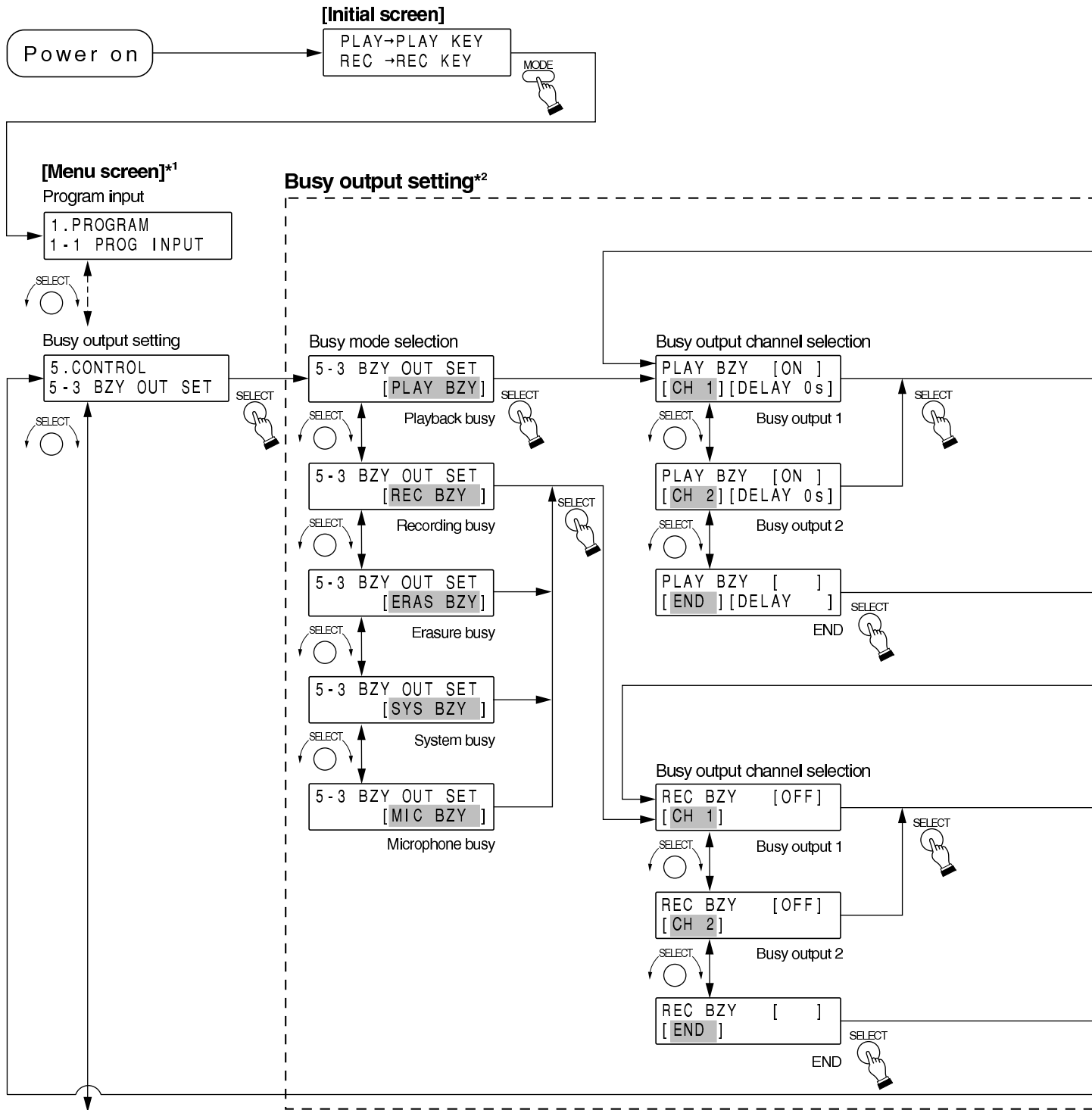

To other menu screen
 (6-1 OPERATION BEEP
 to
 9-1 AUTOMATIC LEVEL ADJUSTMENT)

*1 Pressing the [STOP] key while the menu screen is displayed returns the display to the initial screen.

*2 Pressing the [STOP] key while the function setting screen is displayed returns the display to the previous menu screen.

Note: When the function setting is completed, the screen returns to the menu screen. To terminate all setting operations, further press the [STOP] key to return to the initial screen.

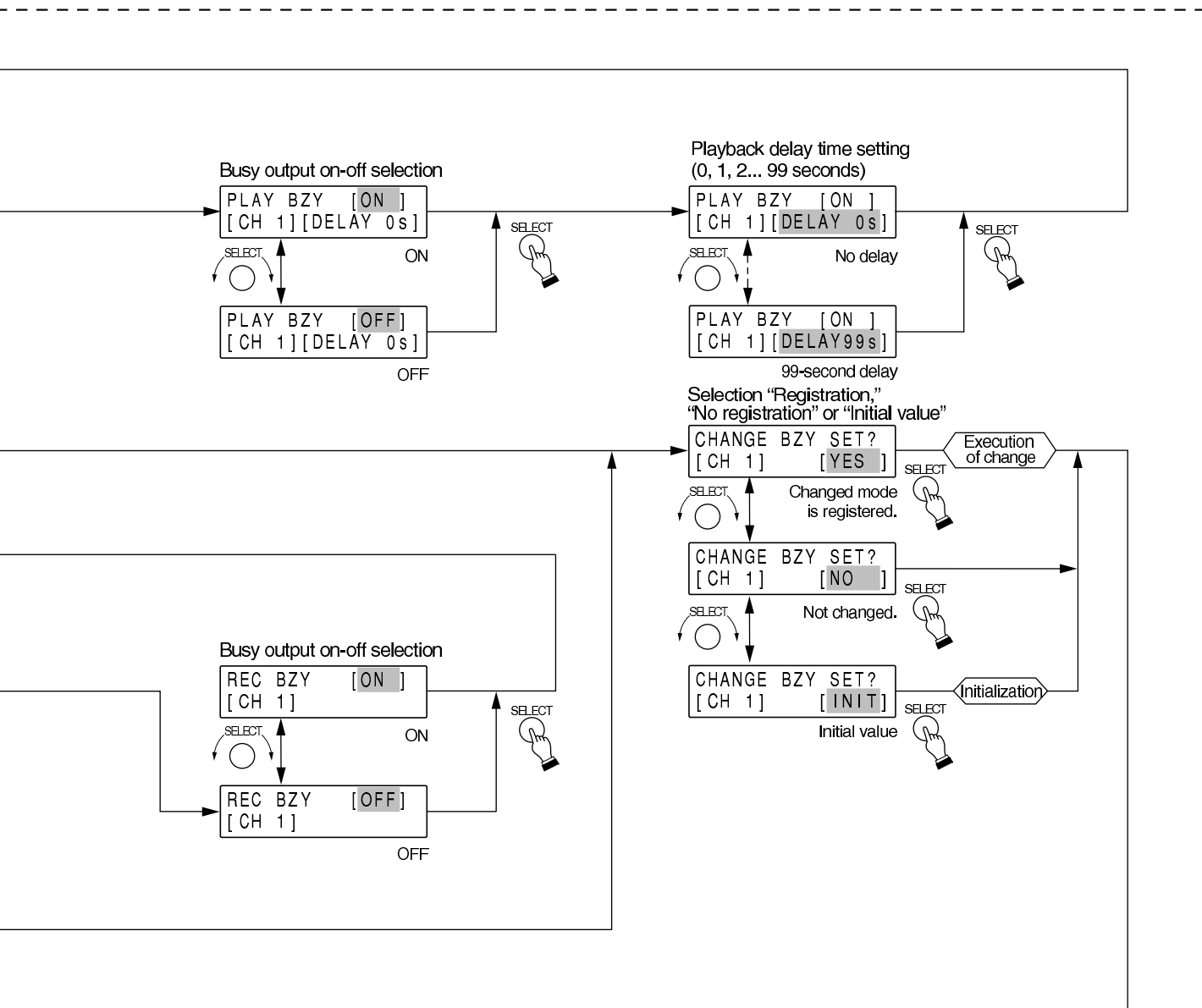

[Selection item and setting contents] (Busy output setting)

Busy mode	Busy output channel	Setting contents	
		Busy output	Playback delay time
Playback busy	Busy output 1	ON	0, 1, 2,99 seconds
	Busy output 2	OFF	
Recording busy	Busy output 1	ON	—
	Busy output 2	OFF	
Erasure busy			
System busy			
Microphone announcement busy			

9.7. Setting Operation (6. ENVIRONMENT SETTING)

9.7.1. Operation procedures (6-1 OPERATION BEEP, 6-2 RS-232C SETTING, 6-3 PASSWORD, 6-4 DIGITAL ANNOUNCER INITIALZATION, 6-5 KEYLOCK and 6-6 VERSION INDICATION)

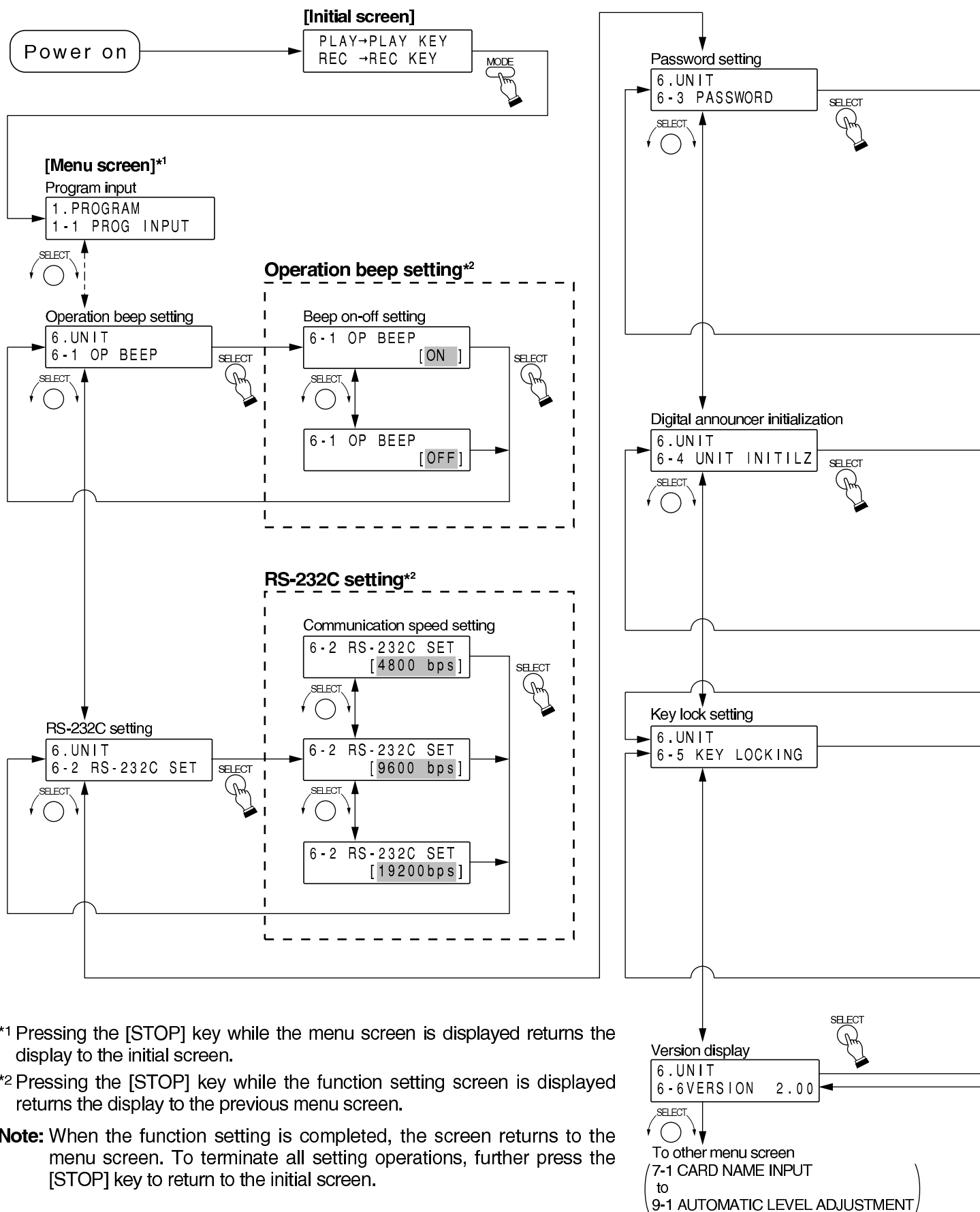

Password setting*2

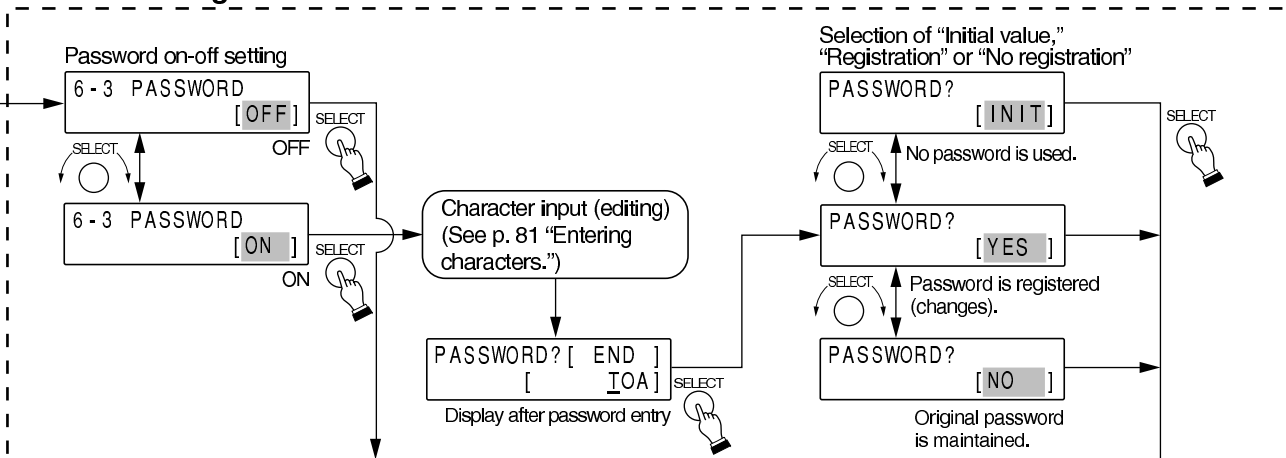

Digital announcer initialization*2

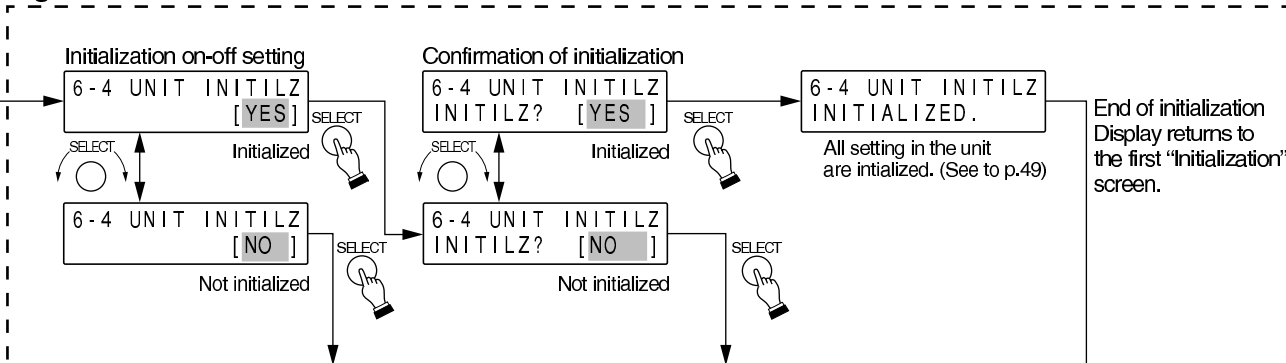

Key lock setting*2

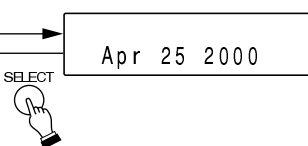
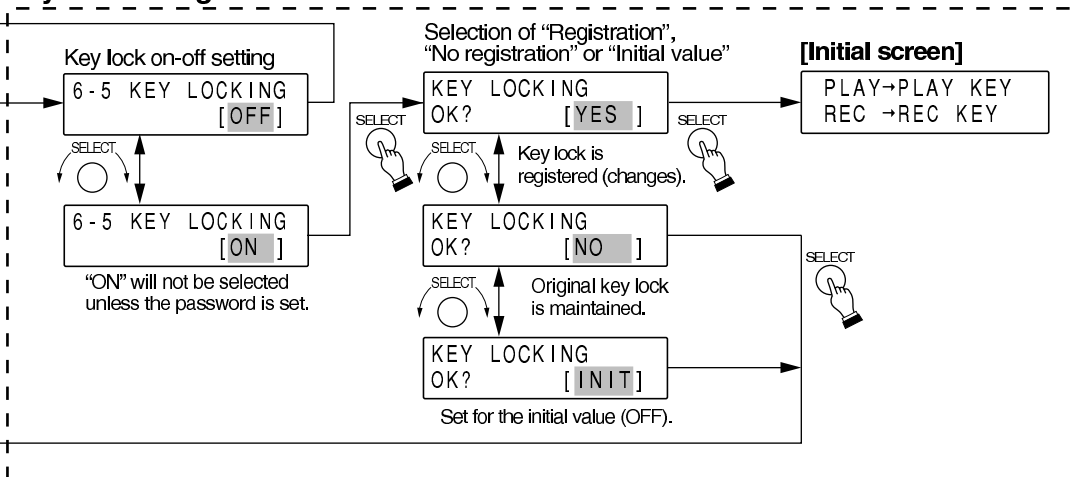

9.8. Setting Operation (7. EDITING THE CARDS)

9.8.1. Operation procedures (7-1 CARD NAME INPUT and 7-2 CARD REFORMATTING)

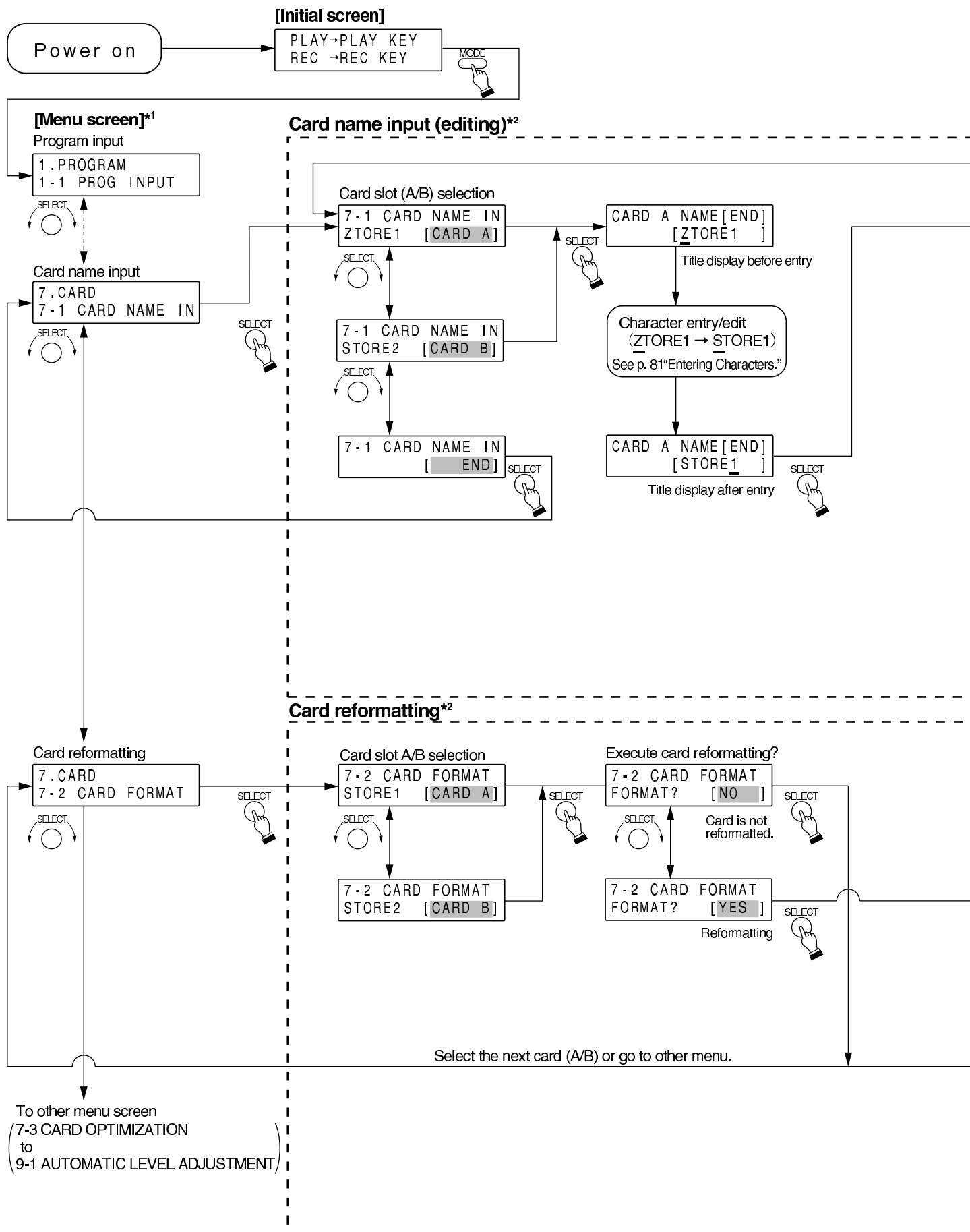

*1 Pressing the [STOP] key while the menu screen is displayed returns the display to the initial screen.

*2 Pressing the [STOP] key while the function setting screen is displayed returns the display to the previous menu screen.

Note: When the function setting is completed, the screen returns to the menu screen. To terminate all setting operations, further press the [STOP] key to return to the initial screen.

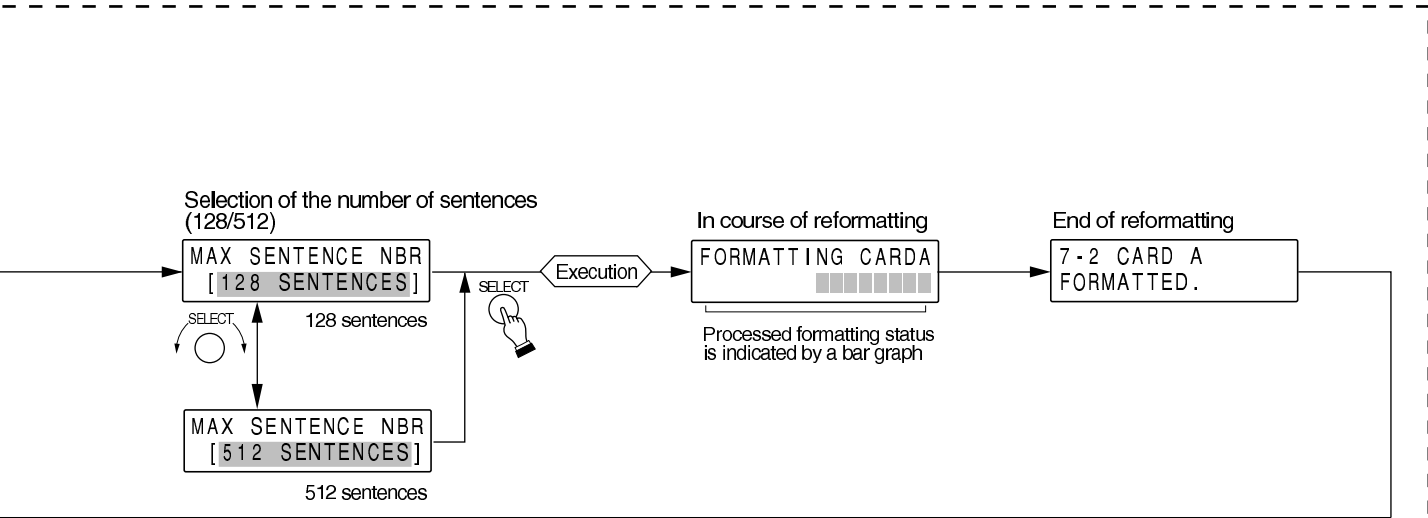
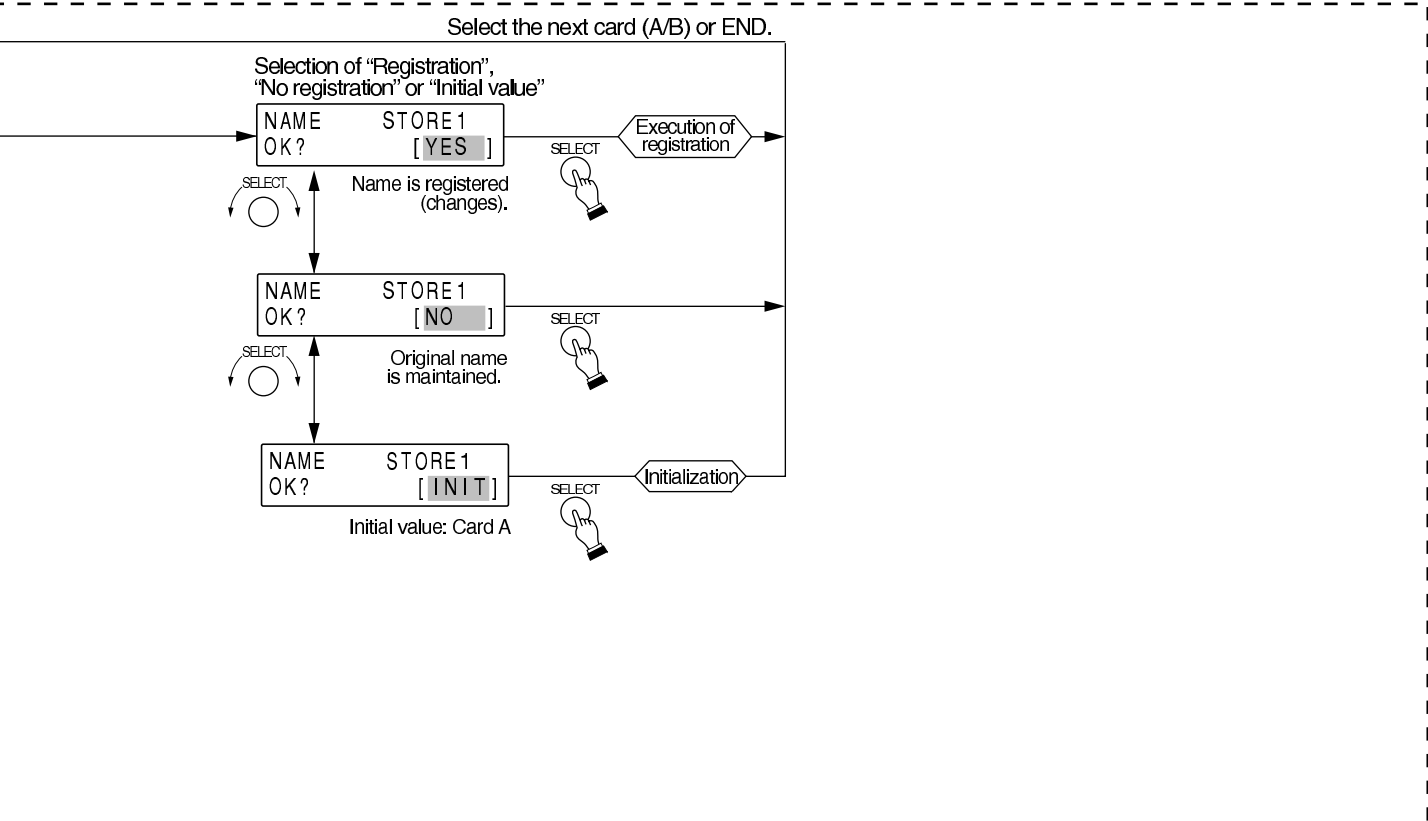

9.8.2. Operation procedures (7-3 CARD OPTIMIZATION and 7-4 SOFTWARE WRITE PROTECT)

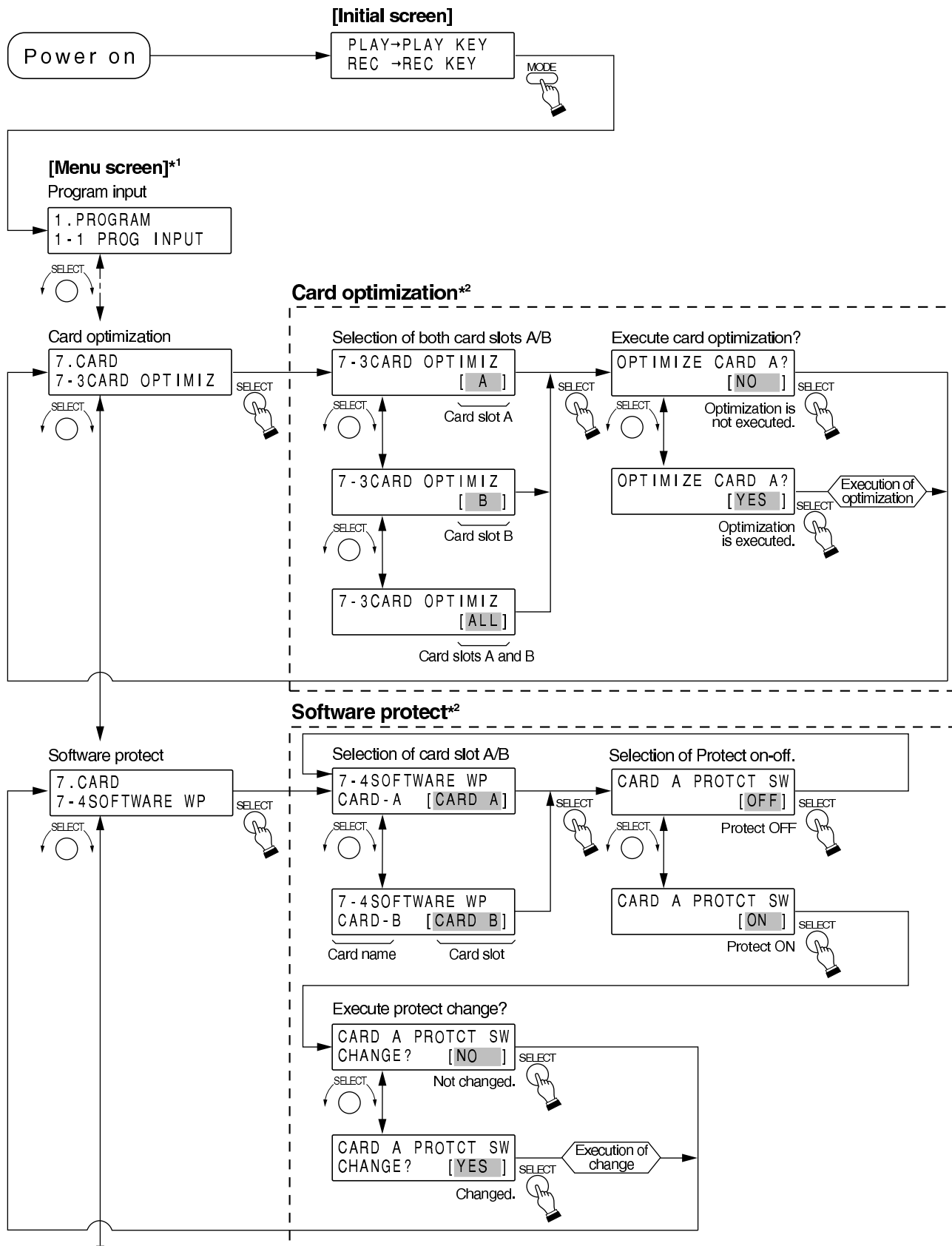

To other menu screen
 (8-1 PROGRAM COPYING to 9-1 AUTOMATIC LEVEL ADJUSTMENT)

*1 Pressing the [STOP] key while the menu screen is displayed returns the display to the initial screen.

*2 Pressing the [STOP] key while the function setting screen is displayed returns the display to the previous menu screen.

Note: When the function setting is completed, the screen returns to the menu screen. To terminate all setting operations, further press the [STOP] key to return to the initial screen.

9.9. Setting Operation (8. COPYING THE PROGRAM, SENTENCE and CARD)

9.9.1. Operation procedures (8-1 PROGRAM COPYING)

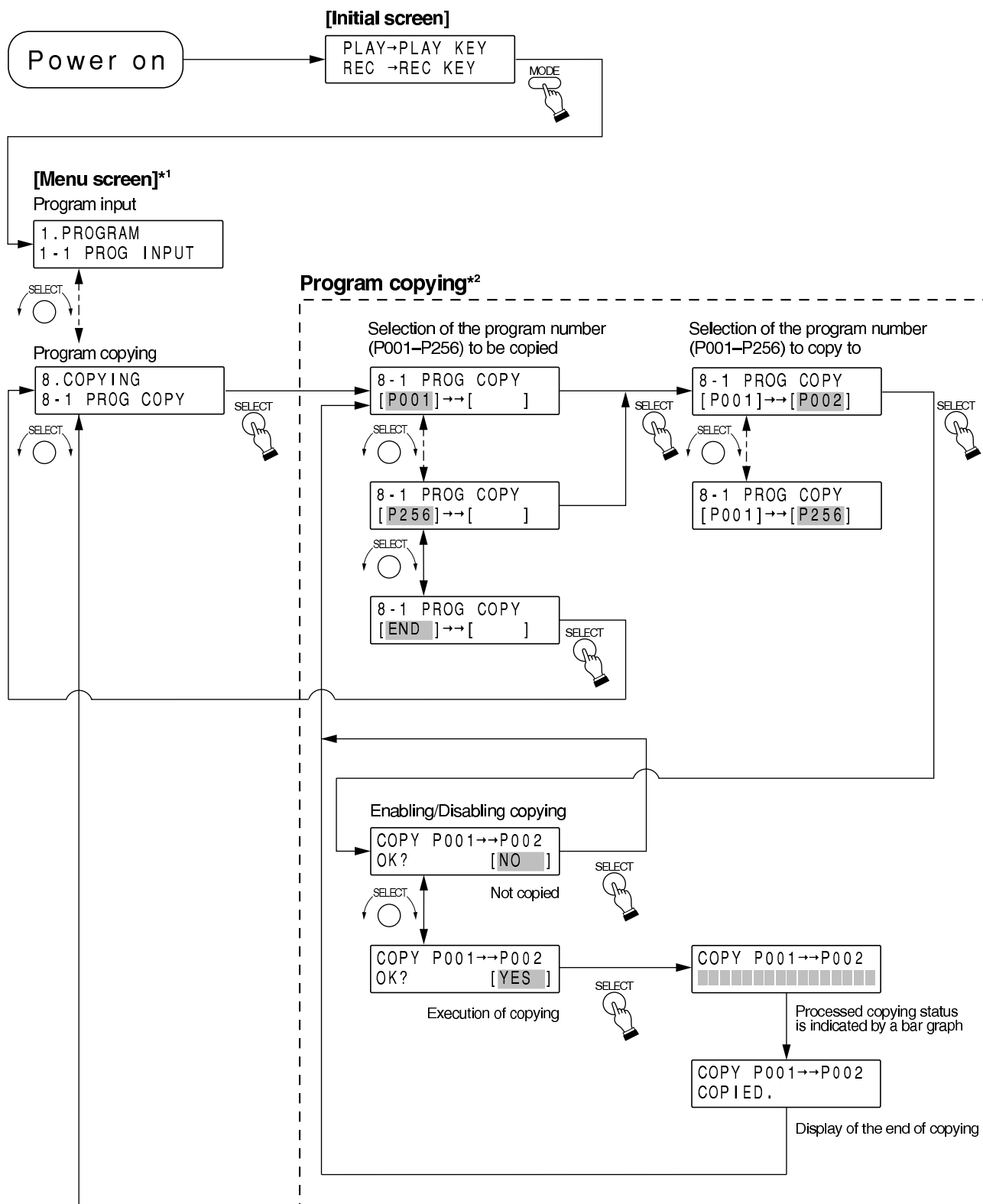

To other menu screen
(8-2 SENTENCE COPYING
to
9-1 AUTOMATIC LEVEL ADJUSTMENT)

*1 Pressing the [STOP] key while the menu screen is displayed returns the display to the initial screen.

*2 Pressing the [STOP] key while the function setting screen is displayed returns the display to the previous menu screen.

Note: When the function setting is completed, the screen returns to the menu screen. To terminate all setting operations, further press the [STOP] key to return to the initial screen.

9.9.2. Operation procedures (8-2 SENTENCE COPYING and 8-3 CARD COPYING)

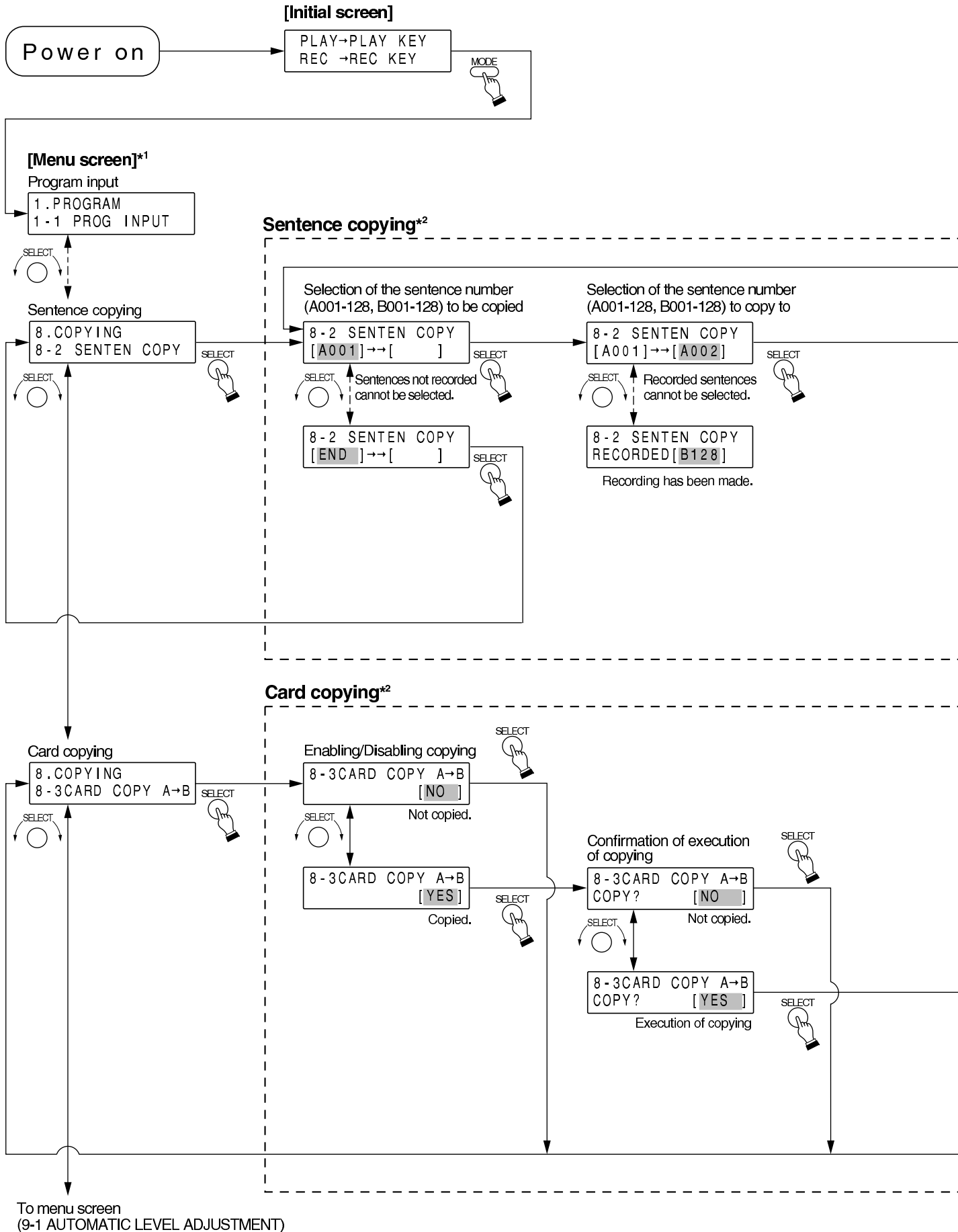

- *1 Pressing the [STOP] key while the menu screen is displayed returns the display to the initial screen.
- *2 Pressing the [STOP] key while the function setting screen is displayed returns the display to the previous menu screen.

Note: When the function setting is completed, the screen returns to the menu screen. To terminate all setting operations, further press the [STOP] key to return to the initial screen.

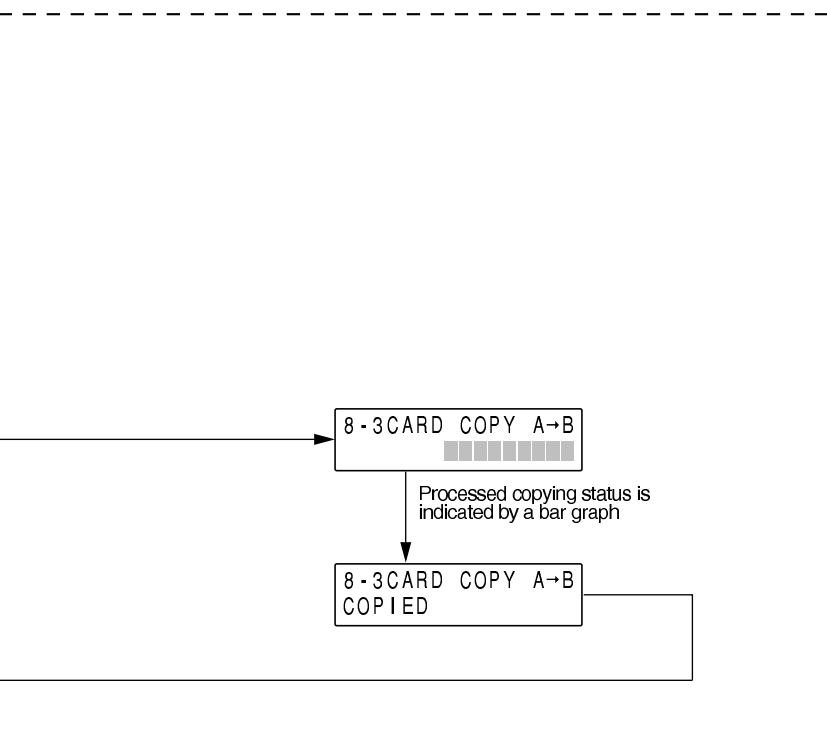
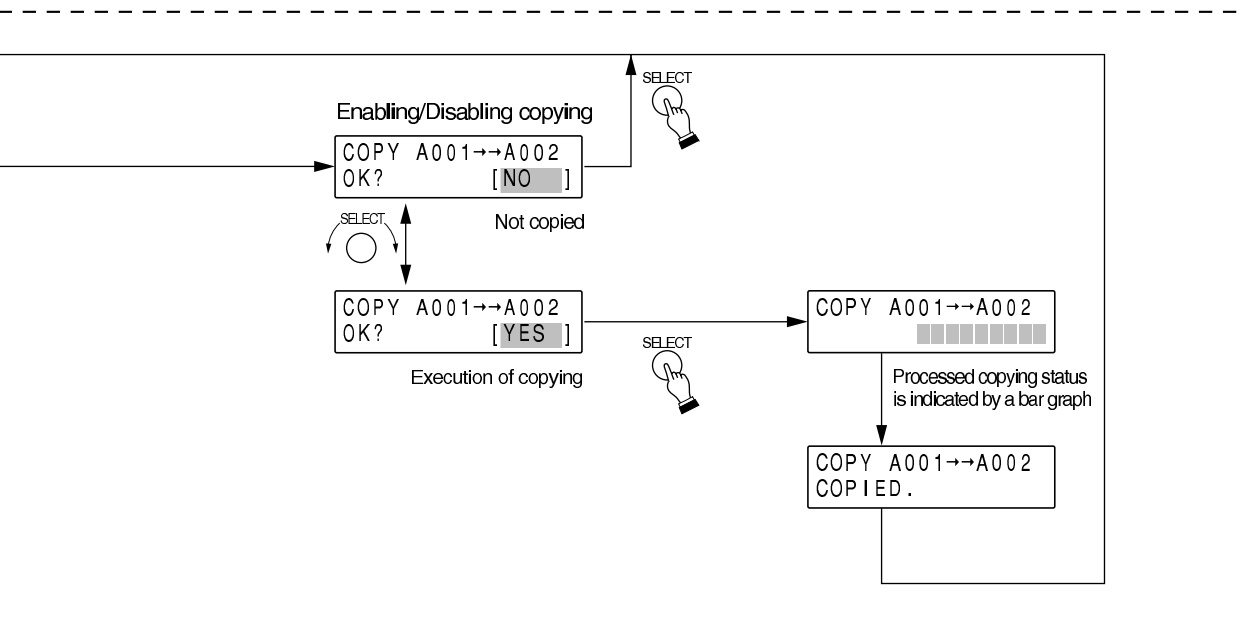

9.10. Setting Operation (9. AUTO-LEVEL SETTING)

9.10.1. Operation procedures (9-1 AUTOMATIC LEVEL ADJUSTMENT)

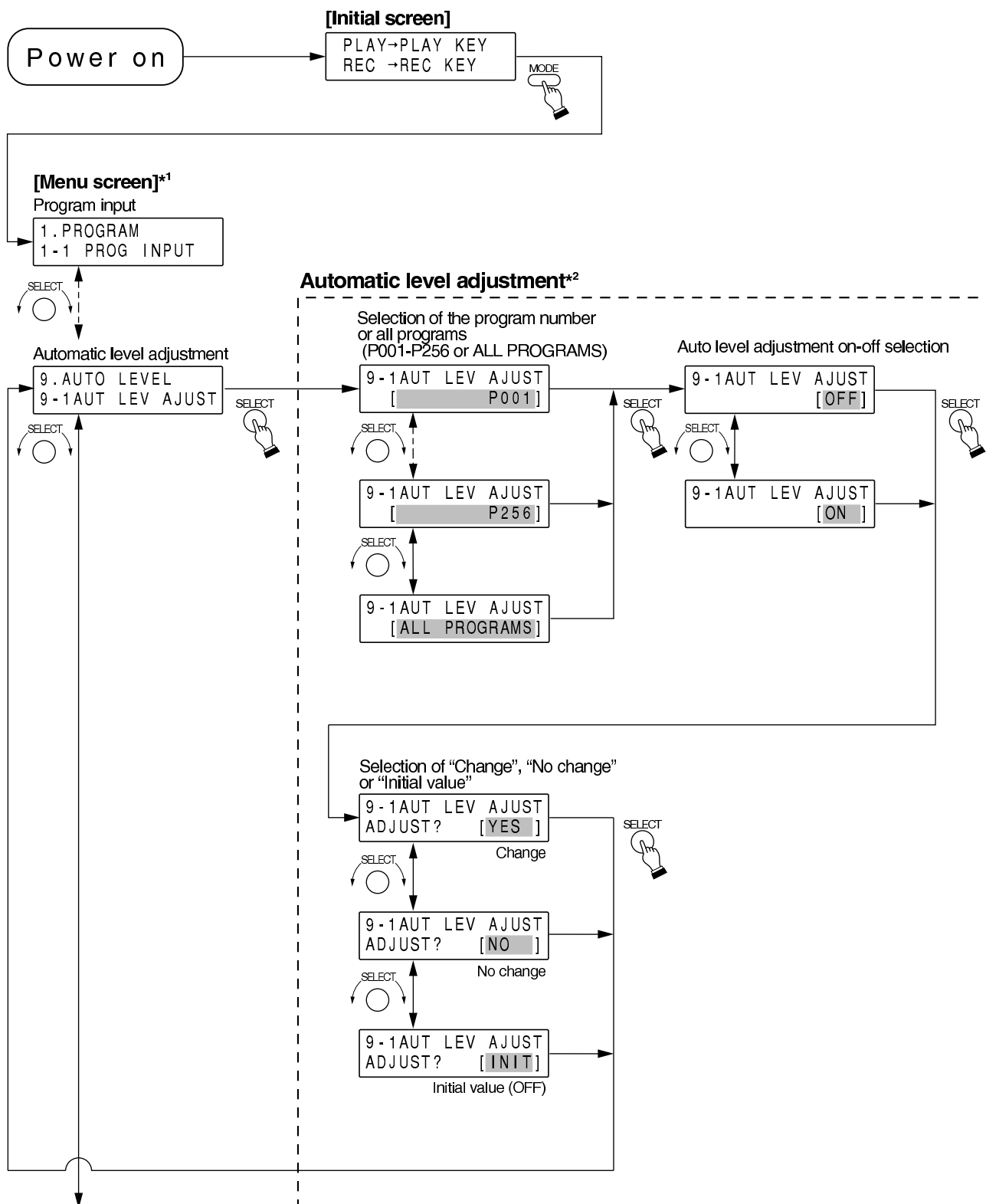

*1 Pressing the [STOP] key while the menu screen is displayed returns the display to the initial screen.

*2 Pressing the [STOP] key while the function setting screen is displayed returns the display to the previous menu screen.

Note: When the function setting is completed, the screen returns to the menu screen. To terminate all setting operations, further press the [STOP] key to return to the initial screen.

9.11. Entering Characters

The sentence title, program title, card name, and password can be input using up to eight alphanumeric characters. To do this, use the [SELECT] dial.

9.11.1. Usable characters and commands

Characters

A	B	C	D	E	F	G	H	I	J	K	L
M	N	O	P	Q	R	S	T	U	V	W	X
Y	Z	a	b	c	d	e	f	g	h	i	j
k	l	m	n	o	p	q	r	s	t	u	v
w	x	y	z	0	1	2	3	4	5	6	7
8	9	!	^	#	\$	%	&	()	-	@
—											

Commands

- [END] Terminates the character input screen.
- [FORWD] Moves the cursor right one character.
- [BACK] Moves the cursor left one character.
- [INS] Inserts a space into the cursor position and shifts text right one character.
- [DEL] Erases the character at the cursor and shifts text left one character.

9.11.2. Character/command display and [SELECT] dial operation

As the [SELECT] dial is rotated, the character/command display changes as follows:

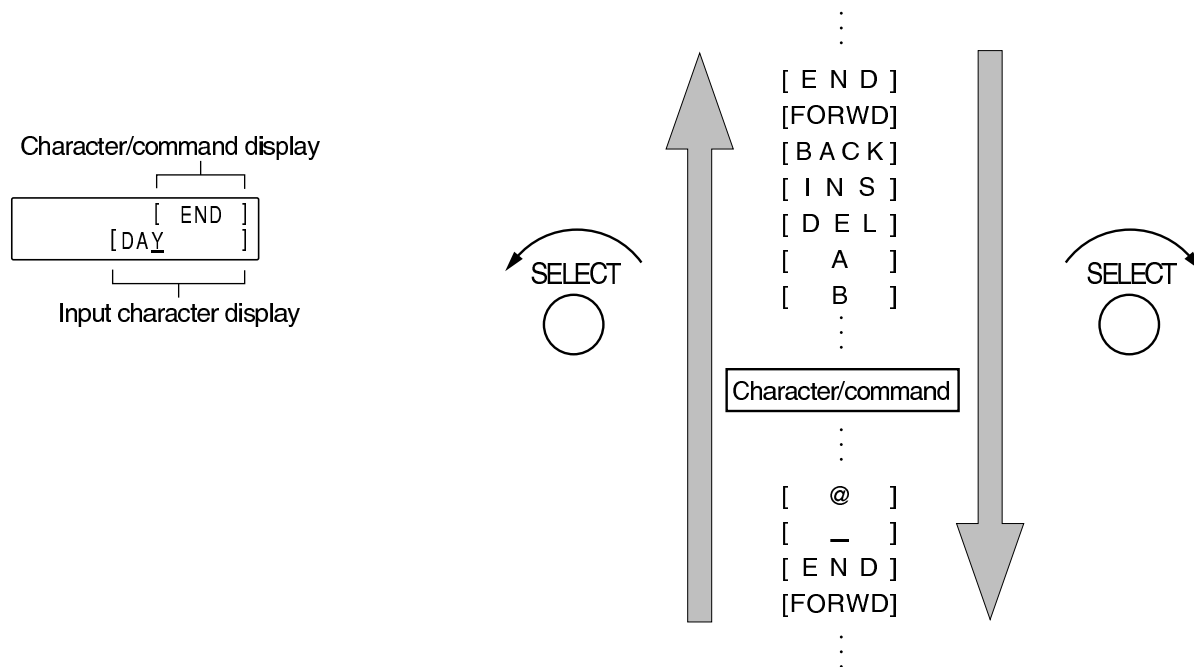

9.11.3. Character input example

In this example, the misspelled word "DEY" has been entered, which is corrected to read as "DAY".

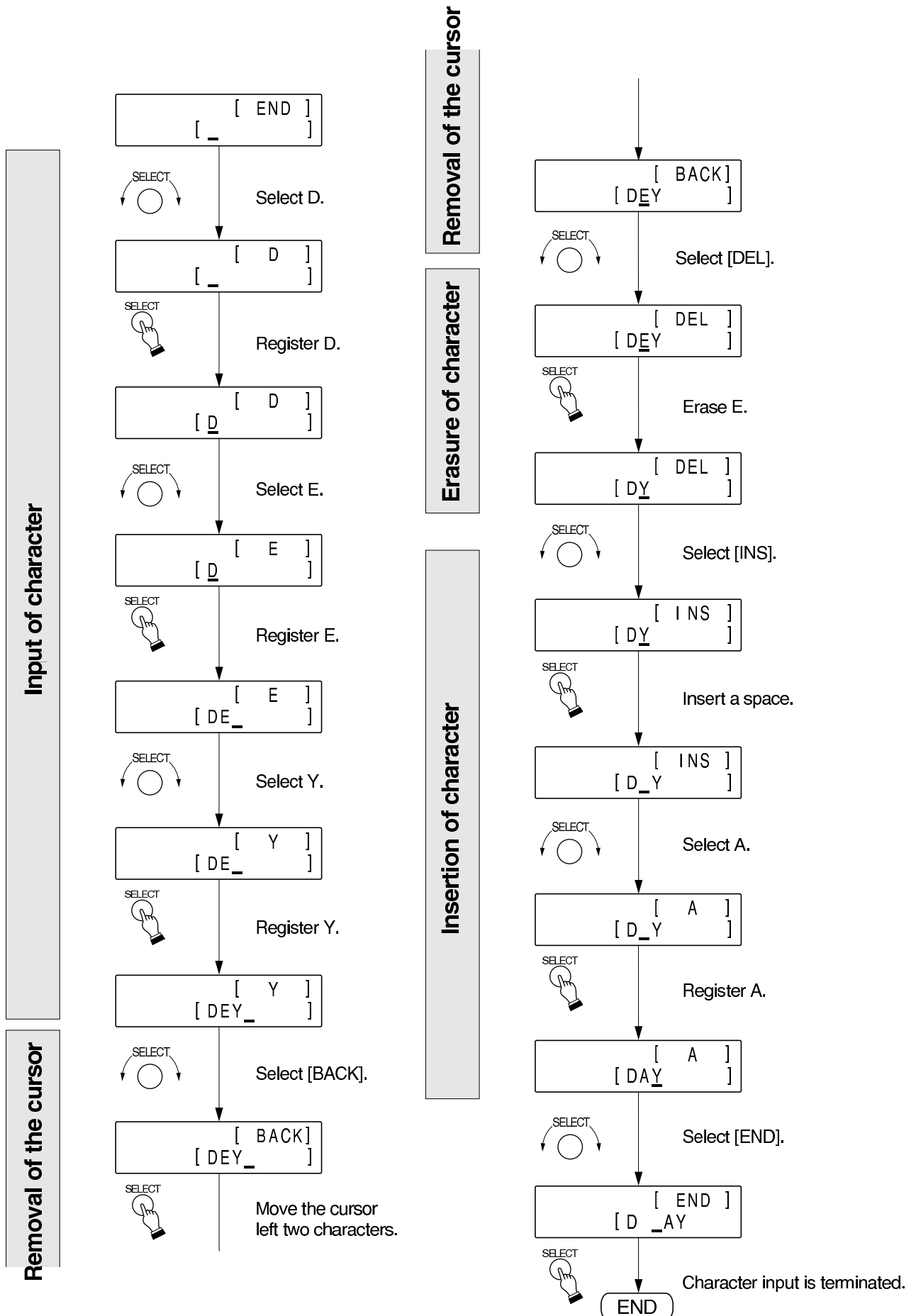

10. MICROPHONE ANNOUNCEMENTS AND SOURCE EQUIPMENT BROADCAST

This unit also permits broadcast from the microphone connected to the microphone input on the front panel, or from external musical equipment connected to the auxiliary input located on both the front and rear panels. Priorities are attached to broadcast as follows.

<Broadcasting priority order>

1. Emergency playback
2. Microphone announcement
3. Program playback
4. Broadcast of external musical equipment

Note: Broadcast cannot be made from the microphone or source equipment during recording. The microphone or external musical equipment can be used only for recording during recording.

10.1. Making Microphone Announcements

Preset the microphone volume control to the minimum position (0).

- (1) Connect the microphone to the microphone input on the front panel.
- (2) Making announcements, adjust the microphone volume control for the most appropriate level.

Note: Program playback sounds are not audible during the microphone announcement. However, the playback continues without stopping.

10.2. Making Source Equipment Broadcast

Preset the auxiliary input volume control to the minimum position (0).

- (1) Connect the external musical equipment to the auxiliary input. The auxiliary input is located on both the front panel (RCA pin jack) and the rear panel (phone jack). Signals to both inputs are internally mixed.
- (2) Playing the external musical equipment, adjust the auxiliary input volume control for the most appropriate level.

11. INSTALLATION

11.1. Connection Examples

When connecting a cassette deck, CD player or other musical equipment or amplifier to the unit or when connecting the unit's power supply, make sure that the power to each equipment is switched off.

11.1.1. Front panel

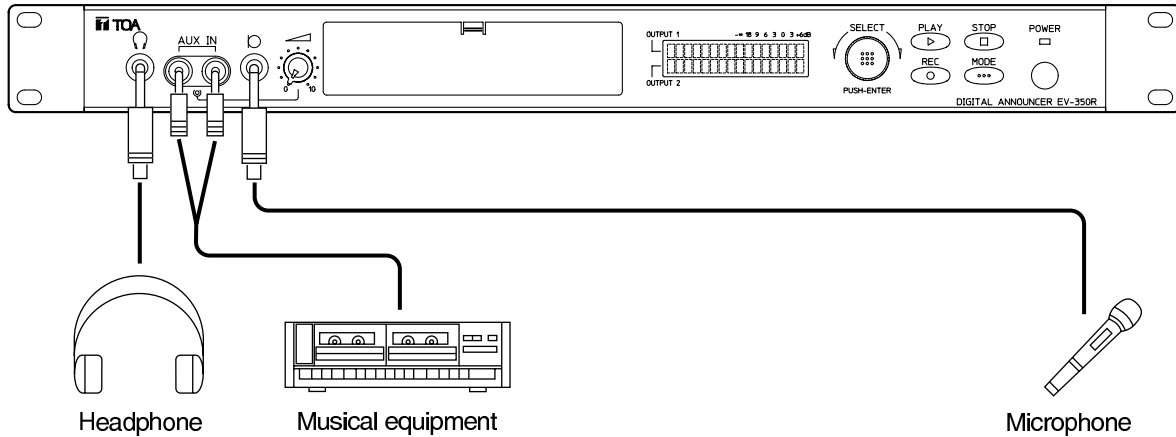

- Signals to both the microphone input and auxiliary input are internally mixed during recording, permitting simultaneous recording of announcements and background music.
- Signals to two auxiliary input terminals on the front panel are internally mixed. Therefore, the stereo output of the musical equipment connected to these terminals changes to the monaural output.
- Signals to the microphone input and auxiliary input are not sent out from Output 1 or 2 during recording. They are only sent out from the headphone output.
- Sounds emanating from Outputs 1 and 2 do not stop even if a headphone is connected to the headphone terminal.

11.1.2. Rear panel

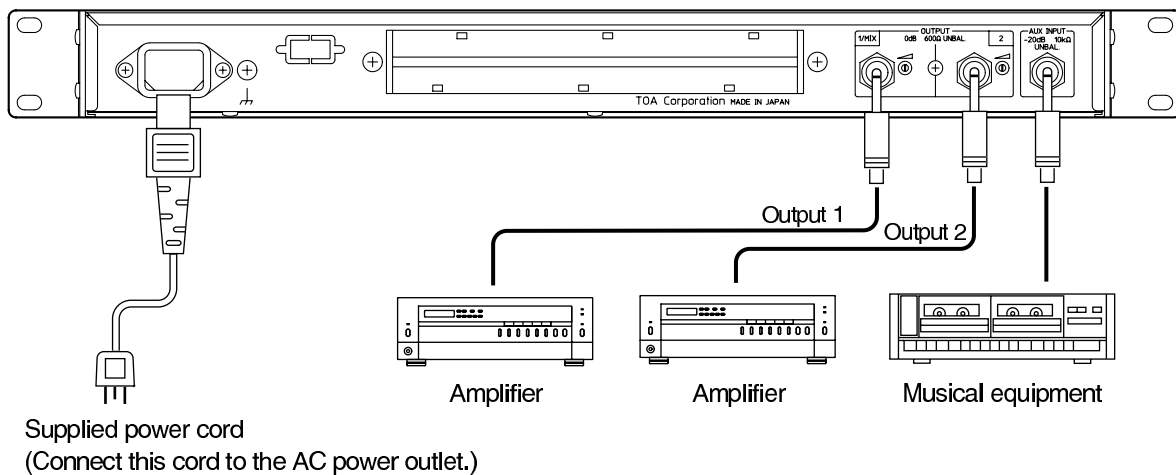

Supplied power cord
(Connect this cord to the AC power outlet.)

11.1.3. Terminal block

[Upper row]

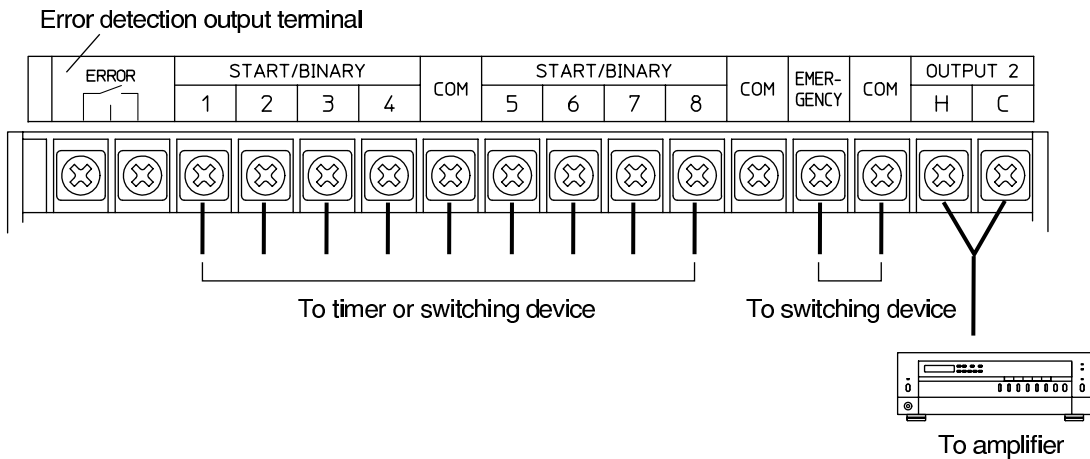

- Outputs 1 and 2 of the terminal block provide the same signal as the phone jack outputs 1 and 2.
- Use the contact input under the condition of no-voltage make contact, 24 VDC for open voltage, 10 mA for short-circuit current, and 50 ms or more for short-circuit time.
- The contact capacity is 30 VDC/500 mA or less when using the busy output.
- Be sure to use a relay contact with enough capacity when directly controlling the amplifier power.

[Lower row]

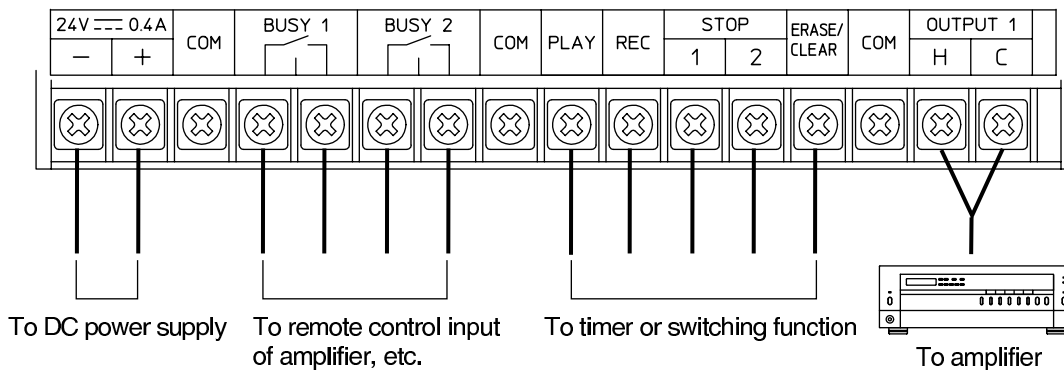

11.1.4. Error detection output terminal

This terminal normally closes.

It breaks when the unit falls into the following states:

- (1) No memory card is inserted into Card Slot A or B.
- (2) The memory card of the type that cannot be used or the faulty memory card is mounted.
- (3) The SRAM memory card's battery drops.
- (4) The unit's power is switched off.
- (5) The unit malfunctions.

As to (1) - (4), the terminal makes if the situation returns to normal.

When the unit malfunctions (5), switch off the power once, then switch on the power again. The terminal makes when the problem is corrected. However, should the unit continue to malfunction, its failure can be considered. In such cases, consult with the shop from where the unit was purchased.

11.2. Mounting the Unit in an Equipment Rack

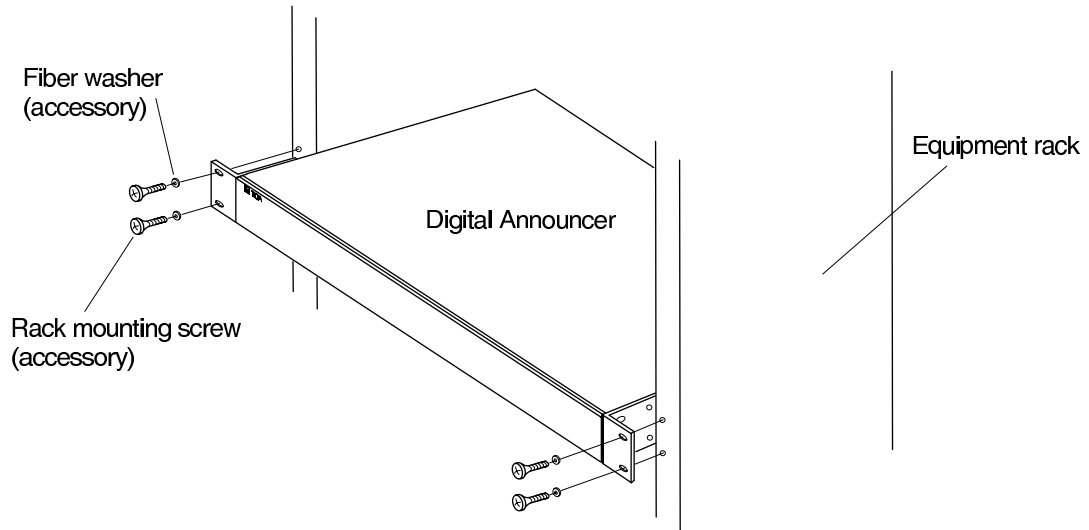

11.3. Attaching Rubber Feet

When installing the unit on the desk, attach the supplied rubber feet to the unit's bottom surface.

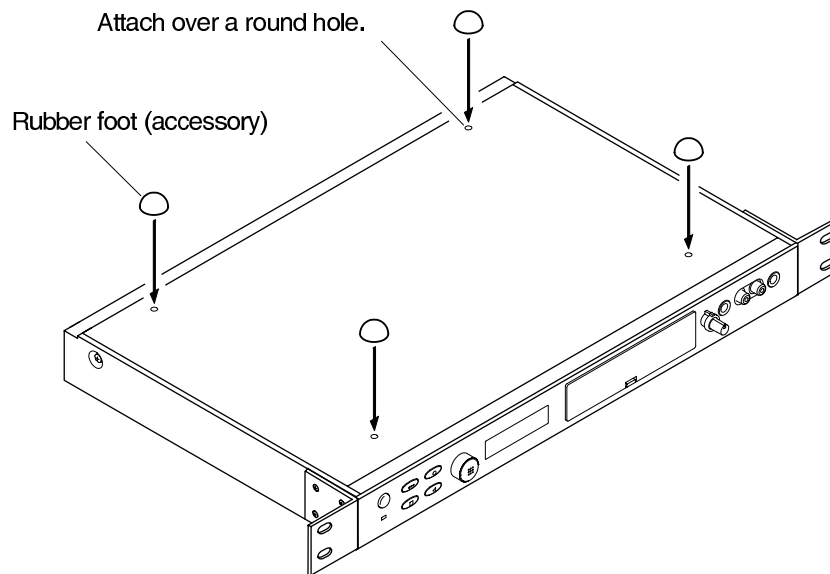

12. SPECIFICATIONS

Power Source	AC mains, 50/60 Hz or 24 V DC 0.4 A
Power Consumption	12 W
Output	Outputs 1, 2 : 0 dB*, 600 Ω, unbalanced, phone jack/screw terminal Headphone output : 0 dB*, 100 Ω, unbalanced, phone jack
Input	MIC : -55 dB*, 600 Ω, unbalanced, phone jack AUX: -20 dB*, 10 kΩ, unbalanced, phone jack/RCA pin jack
Mountable Memory Card No.	2 (Slots A/B) Note: Memory cards are optional.
No. of Recording Sentence	When one card is installed: 128 or 512 sentences (changeable) When two cards are installed: 256 or 1024 sentences (changeable) 1 emergency sentence, other than the above sentences, can be recorded. When recorded by a control input: 8 (direct mode) or 256 (binary mode) (changeable)
Recording Sound Quality	Sampling frequency : 32 kHz or 44.1 kHz Recording grade : Long (bit rate 64 kbps), Normal (bit rate 96 kbps), High (bit rate 128 kbps) or Extremely High (bit rate 192 kbps)
Playback Mode	Single-source mono or dual-source mono (changeable)
No. of Playback Programs	Direct control: 8 programs or Binary control: 256 programs 1 emergency message takes precedence over the above programs and is played back.
Control Input	Activation 1-8, playback, pause 1, pause 2, emergency, recording, erasure: No-voltage make contact, 50 ms or more, open voltage 30 V DC, short circuit current 10 mA, screw terminal RS-232C terminal: D-sub connector (9 pins)
Control Output	Busy outputs 1, 2 and Error detection output: Screw terminal, contact capacity 30 V DC 0.5 A
Display	16 characters x 2 lines, LCD with backlight
Frequency response	20 - 20,000 Hz (sampling at 44.1 kHz) 20 - 14,000 Hz (sampling at 32 kHz)
Distortion	Under 0.3% (44.1 kHz, recording method: Extremely High)
Finish	Panel: Aluminum, black 30% glossy Case : Surface treated steel plate, black 30% glossy
Weight	4 kg

The above specifications are subject to change without notice.

* 0 dB=1 V

● Accessories

Power cord	1
Unbalanced-phone plug cord (2 m)	2
Rack mounting screw	4
Rack mounting washer	4
Rubber foot	4

Traceability Information for Europe (EMC directive 2004/108/EC)

Manufacturer:

TOA Corporation
7-2-1, Minatojima Nakamachi, Chuo-ku, Kobe, Hyogo,
Japan

Authorized representative:

TOA Electronics Europe GmbH
Suederstrasse 282, 20537 Hamburg,
Germany

